



# HANDBOOK ON BARRIER FREE AND ACCESSIBILITY



**CENTRAL PUBLIC WORKS DEPARTMENT**

Year : 2014  
(URL : <http://cpwd.gov.in>)



सत्यमेव जयते

# HANDBOOK ON BARRIER FREE AND ACCESSIBILITY



Published by  
Directorate General  
Central Public Works Department



# HANDBOK ON BARRIER FREE AND ACCESSIBILITY

January 2014

Any Part of the publication may be transmitted or reprinted

Only with due acknowledgement

## **Published by:**

Directorate General

Central Public Works Department

101 A, Nirman Bhawan, New Delhi-110001

Email: cpwd\_dgw@nic.in

## **Prepared by:**

Chief Architect (NDR)

Central Public Works Department

New Delhi

Email: cpwdcandr@gmail.com

## **Technical Advisory Team: CPWD**

Rajesh K. Kaushal, Chief Architect (NDR)

Naveen Bhatnager, Architect (Hq cum Planning)

Ms Nidhi Anand, Deputy Architect

Govind Ram, Computer Operator

## **Printed by:**

Arti Printers

3/55, ODS, Lajpat Nagar-IV,

New Delhi-110024

Tel.: 011-26435990

Email: artiprinters2010@gmail.com



शहरी विकास एवं संसदीय कार्य मंत्री  
भारत

MINISTER OF URBAN DEVELOPMENT  
AND PARLIAMENTARY AFFAIRS  
INDIA



श्री कमल नाथ  
Sh. Kamal Nath

### MESSAGE

The CPWD is bringing out a "Handbook on Barrier Free and Accessibility" as ready reckoner Handbook for Architects to make our built environment barrier-free and accessible to all. Access to public areas is not only a matter of pride but also a fundamental right of every person in our country.

This effort aims to bring about awareness on issues faced by differently abled persons when using public buildings and spaces. It also incorporate concerns of older people and children which professionals should factor in so as to create a barrier-free environment.

I call upon the Architects and Professionals community to grasp, promote and use these easy design solutions to make our buildings accessible and safe.

I congratulate CPWD on bringing out this publication.

(Kamal Nath)





शहरी विकास मंत्रालय  
भारत सरकार  
MINISTRY OF URBAN DEVELOPMENT  
GOVERNMENT OF INDIA



डा. सुधीर कृष्णा  
**Dr. Sudhir Krishna**

## FORWARD

Today people with disabilities are in the mainstream of society. A society in which the opportunities are the same for everyone is enriched by the diversity of its active and contributing members. A well-designed environment which is safe, convenient, comfortable, and readily accessible benefits everyone. Therefore Accessibility programs must include good facility design and broad-spectrum approaches that avoid stigmatizing or discriminating against persons with disabilities.

I compliment the Central Public Works Department in bringing out this publication “Handbook on Barrier Free and Accessibility”. It marks another milestone in the journey with social policies towards “Differently able people” and creating “Non-Discriminate in the Built Environment”. This document gives guidelines and solutions for accessibility in a built environment. It is designed both as a working tool to provide a common point of reference and as a means to increase the awareness of the needs of people with disabilities and the elderly. Practical low cost solutions to retro-fitting existing buildings are discussed, as well as the methods used to assess the suitability of an existing building, to improve access for disabled people. Specific products and designs are illustrated and discussed

It is anticipated that design professionals, the building industry, government, the community as a whole will take these guidelines and implement them and will go a long way in creating awareness about the importance of Barrier Free Built Environment and help Professionals in this field as an effective guide.

**Sudhir Krishna**  
Secretary  
Ministry of Urban Development  
Government of India





वी. के. गुप्ता  
V. K. Gupta

## ABOUT THE BOOK

We are all physically disabled at some time in our lives. A child, a person with a broken leg, an elderly person, etc. are all disabled in one way or another. As far as the built-up environment is concerned, it is important that it should be barrier-free and adapted to fulfill the needs of all people equally.

After the enactment of “The Person with Disabilities (Equal Opportunities, Protection of Rights and Full participation) Act, 1995 by Govt. of India.” There is a provision of Act under “Non-discriminate in the built environment” Chapter VIII Section 46.

CPWD being the single largest Govt. department provides single window services for all facets of Government built environment in India & abroad, is not indifferent with respect to Government of India policies towards “Differently able people”.

CPWD played proactive role and take leadership role in making Barrier Free Environment and set a benchmark for others to follow. In fact CPWD had taken out first publication “Guidelines and Space Standards for Barrier free built Environment for Disable and Elderly Persons” in 1998 where Architectural standards were spell out in detail and guided MoUD in framing “Barrier Free Environment in the Public Building for Persons with Disabilities” notification on 28.08.2002.

CPWD had made a provision in CPWD manual for Barrier Free environment so that all Architect and Engineers shall mandatorily follow.

CPWD played a proactive role in conducting “Access Audit Report” by NGO to facilitate Barrier Free Provision in existing Government Buildings by implementing its recommendations.

CPWD played a major role to bring out “Monograph on Policy and Programmes of Ministry of Urban Development for Elderly and Person with Disability” by M/o Urban Development, a compendium of all Act and notification.

This publication “Handbook on Barrier Free and Accessibility” is a design guide made for the purpose of providing Design Professionals with the basic information and data necessary for a barrier-free environment.

I look forward to the widespread dissemination and use of this Handbook and feedback on the same.

V.K. Gupta  
Director General  
Central Public Works Department  
Ministry of Urban Development  
Government of India







विजय मोटवानी  
**Vijay Motwani**

## INTRODUCTION

India has millions of people suffering from one or the other kind of disability. The Persons with Disabilities Equal Opportunities, Protection of Rights and Full Participation Act of 1995 heralded a new dawn in the lives of disabled people. For the first time in independent India, a separate law has been formulated which talks about the multiple needs of disabled people. The Act stipulates that the Governments, local authorities ensure provisions of barrier-free facilities in all new Government buildings and public utilities, roads and transport.

Today accessibility for all is recognized as a basic necessity, and there are attempts all over the world to ensure this. Barrier-free features are now becoming fundamental to all design concepts. The awareness level about the necessity of barrier-free access needs to be raised. The existing code must be effectively implemented to break barriers, open doors for an inclusive society. This new design approach will provide a barrier-free environment for all.

We, as committed and concerned professionals, should take up this responsibility of addressing these issues and demonstrate through our work the benefits of a barrier-free environment.

It is hoped that “Handbook on Barrier free and Accessibility” will help in bringing us as closer to our goal of an inclusive, barrier free and rights based society as possible.

**Vijay Motwani**  
Special Director General (DR)  
Central Public Works Department  
Ministry of Urban Development  
Government of India





सिप्रा मितरा  
**Sipra Mitra**

## PREFACE

Historically, our society has isolated and segregated people with disabilities, and despite some progress, their full civil, political, economic, social, cultural and development rights. This is largely due to widespread ignorance and prejudice in our society. People with disabilities are entitled to help and assistance in order to avert, eliminate or improve their disability. The general goal is to overcome, as much as possible, the disability's effects and to enable the disabled to participate in all areas of society.

Builders, Architects and Professionals are the users of this handbook; to ensure the specific environment created is suitable for all categories of people. The standard also indicates that barrier free design can be achieved without economic burden.

The handbook is simple and easy to adopt and widespread dissemination to reach out various Professionals adding to our effort in making Built environment Barrier Free and Accessible to all.

  
**Sipra Mitra**

Additional Director General (Arch)  
Central Public Works Department  
Ministry of Urban Development  
Government of India





राजेश कुमार कौशल  
**Rajesh K. Kaushal**

## **ACKNOWLEDGEMENT**

The Central Public Works Department (CPWD) is a 159th years old Institution and providing comprehensive services including Architectural Planning, Designing, Construction and Maintenance of Office & Residential Buildings.

A need was felt to publish "Handbook on Barrier Free and Accessibility" for developing clear and concise technical design guidelines for creating Barrier-free spaces through Architectural Designs which eliminate the type of barriers and hindrances that deter physically limited persons from having access to and free mobility in and around a built environment.

I wish to show my deep gratitude to the esteemed Director General, CPWD, Sh. V.K.Gupta and Additional Director General (NDR) Sh. Vijay Motwani for agreeing to publish this book. I also express my deep appreciation to Sh. Naveen Bhatnagar Architect (Hq cum Planning) and Ms. Nidhi Anand Deputy Architect, SA (NDR-III), CPWD, who made their sincere efforts in bringing out this publication.

Special mentioned must be made for M/s Arti Printers for untiring efforts in printing the Handbook.

**Rajesh K. Kaushal**  
Chief Architect (NDR)  
CPWD, New Delhi.

# CONTENTS

---

<b>Chapter -1</b>	Access Route.....	<b>1</b>
<b>Chapter -2</b>	Ramps.....	<b>4</b>
<b>Chapter -3</b>	Dropped Kerbs.....	<b>5</b>
<b>Chapter -4</b>	Staircases.....	<b>7</b>
<b>Chapter -5</b>	Handrails.....	<b>9</b>
<b>Chapter -6</b>	Corridor, Lobby & Pathways.....	<b>12</b>
<b>Chapter -7</b>	Doors.....	<b>17</b>
<b>Chapter -8</b>	Toilets.....	<b>20</b>
<b>Chapter -9</b>	Bathrooms & Shower Compartments.....	<b>23</b>
<b>Chapter -10</b>	Signage.....	<b>25</b>
<b>Chapter -11</b>	Public Information or Reception Counters.....	<b>29</b>
<b>Chapter -12</b>	Illumination.....	<b>30</b>
<b>Chapter -13</b>	Lifts.....	<b>31</b>
<b>Chapter -14</b>	Escalators and Passenger Conveyors.....	<b>34</b>
<b>Chapter -15</b>	Other Building Services.....	<b>35</b>
<b>Chapter -16</b>	Anthropometrics.....	<b>40</b>
<b>Chapter -17</b>	Car Parking.....	<b>44</b>
<b>Chapter -18</b>	Implementation of Barrier free Provisions.....	<b>47</b>
<b>Chapter -19</b>	Case Study on making Indira Paryavaran Bhawan a Barrier Free Building.....	<b>50</b>
<b>Chapter -20</b>	International Practices in Barrier Free Standards.....	<b>51</b>
<b>Chapter -21</b>	Relevant Extract From National Building Code 2005.....	<b>56</b>
<b>Chapter -22</b>	Relevant extract from Ministry of Urban Development and Poverty Alleviation (Delhi Division) Notification.....	<b>64</b>

---

# Chapter -1 Access Route

This Chapter aims to ensure proper access for all people, with or without disabilities to approach, enter or leave a building independently to reach and use its facilities, such as foyers, lifts, toilets, offices, residential apartments, etc. without undue difficulty.

An easily identifiable continuous and relatively level path free from obstruction or any kind of hazards shall be provided for persons with a disability to enter, move within and leave a building to reach the accessible facilities.

## Provision of Access Route

Access shall be provided from a prominent point or points on the plot boundary,

- Which is accessible to a public street or pedestrian way, directly to at least one entrance.
- Which is commonly used by the public or to a point directly adjacent to one entrance.
- Which is commonly used by the public and to an accessible lift, unless it is impractical to do so because of difficult terrain or unusual characteristics of the site.

In case where the main entrance is not an accessible entrance or it is impractical to provide a commonly used entrance at prominent point on the plot boundary due to difficult terrain or unusual characteristics of the site (e.g. in the case of a sloping site or presence of steep access road/driveway), this would be acceptable provided those persons with a disability could reach the building by means of vehicle and adequate directional signs shall be posted at prominent location of the main entrance to show clearly the location of and the route to an accessible entrance.

## Requirements for Access Route

### Width

The clear width of an access route shall be not less than 1200 mm. and for two way traffic it should be 1650mm-1800mm wide.

### Free from Barriers

Such access shall be free from protrusion hazards, steps, kerbs other than dropped kerbs, steep ramps, doors or doorways which will impede the passage of a wheelchair, or other form of barrier which will prevent access by persons with a disability.

### Surface

The surface of an access route shall be firm and non-slippery.

### Tactile Guiding Path

Tactile guiding path is required to ensure visually impaired person familiarize with the road and path. It shall be avoided with the vehicular movement

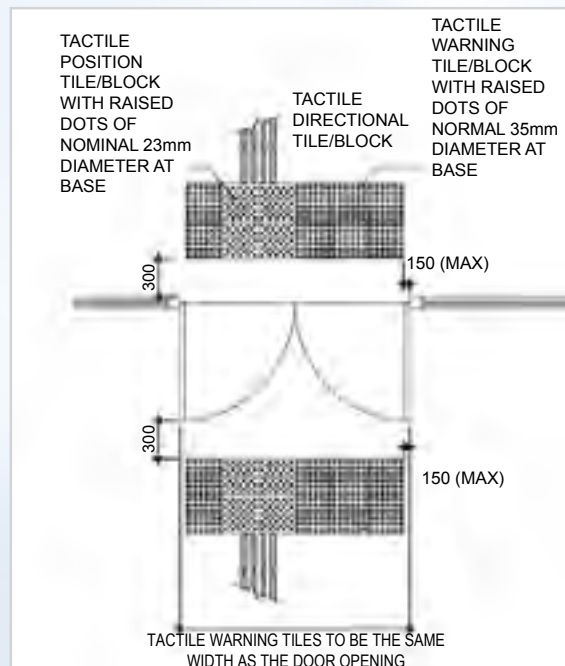

(a) Tactile warning strip at single action door entrance.



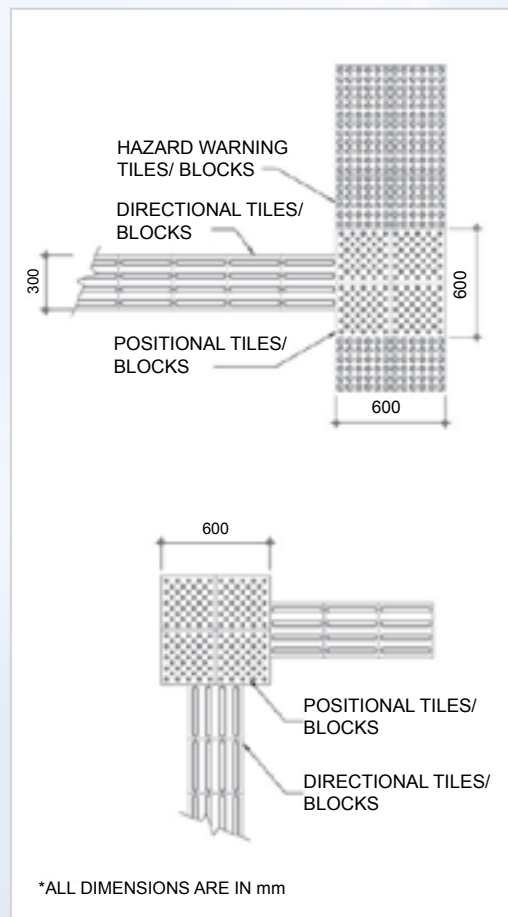
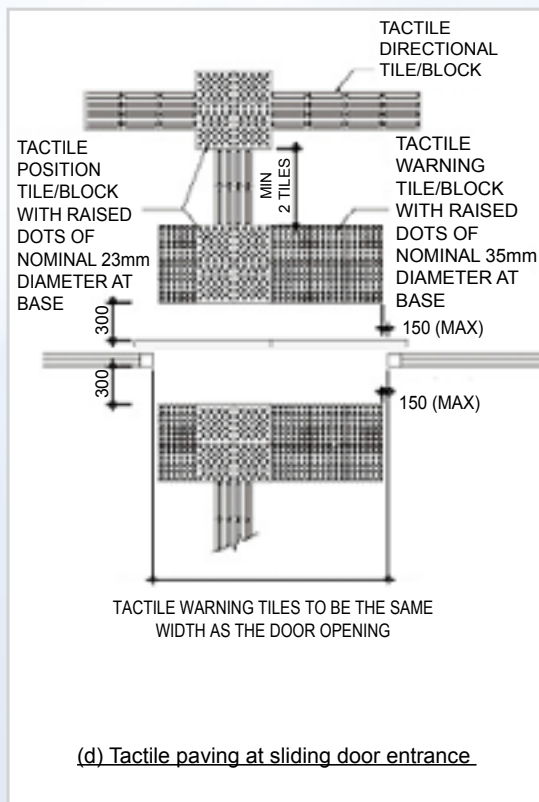
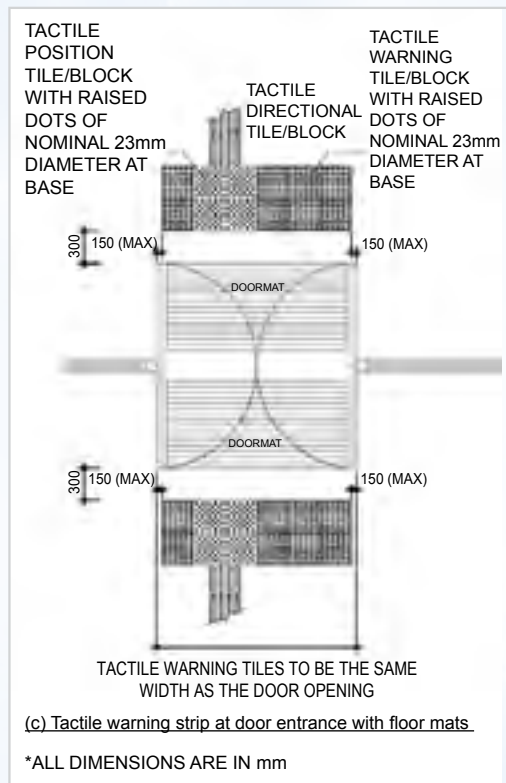
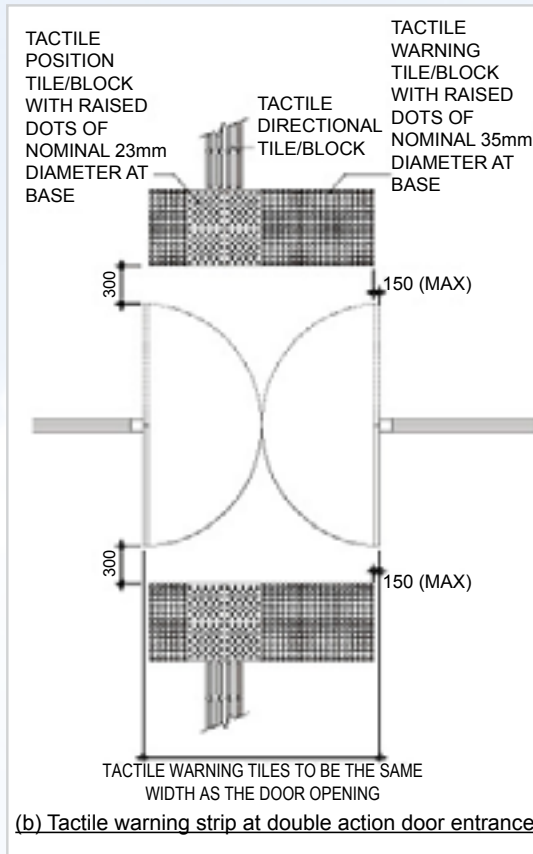

Three kinds of tactile tiles/blocks are commonly used in constructing a tactile guide path:

### Directional Tile/Block

This has parallel raised bars for guiding the users along an intended safe path.

### Hazard Warning Tile/Block

This has raised big dots (35mm in diameter) arranged in square grid parallel to the sides of the slab for indication of potential hazards ahead. This type of tile/block could be used alone to form tactile warning strips at the top and bottom ends of staircase or ramps, and at dropped kerb.

### Positional Tile/Block

This has raised small dots (23mm in diameter) placed in staggered positions for indication of possible change in walking directions.

## Design Considerations

1. In designing an access to the building, it should be recognized that changes in level are difficult for many people to negotiate, including wheelchair users, people who use walking aids and persons with visual impairment.
2. Access routes from the plot boundary to the entrance of a building should be wide enough to allow wheelchair users and other users to pass simultaneously.
3. Easily identifiable access route e.g. tactile guide path for persons with visual impairment should be provided from the plot boundary to the entrance of a building.
4. Indication signage for accessible entrances should be provided where more than one entrance exist in a complex building.

## Recommended Design Requirements

### Width

The clear width of the access route should not be less than 1200 mm.

### Floor Space

In large floor space of more than 200 sq.m. where the cues of physical edges such as walls and handrails are not present, tactile guide paths should be used to facilitate orientation of persons with visual impairment.

### Surface

The surface of the access should be firm and slip-resistant with a “static coefficient of friction” of “Good” grading.

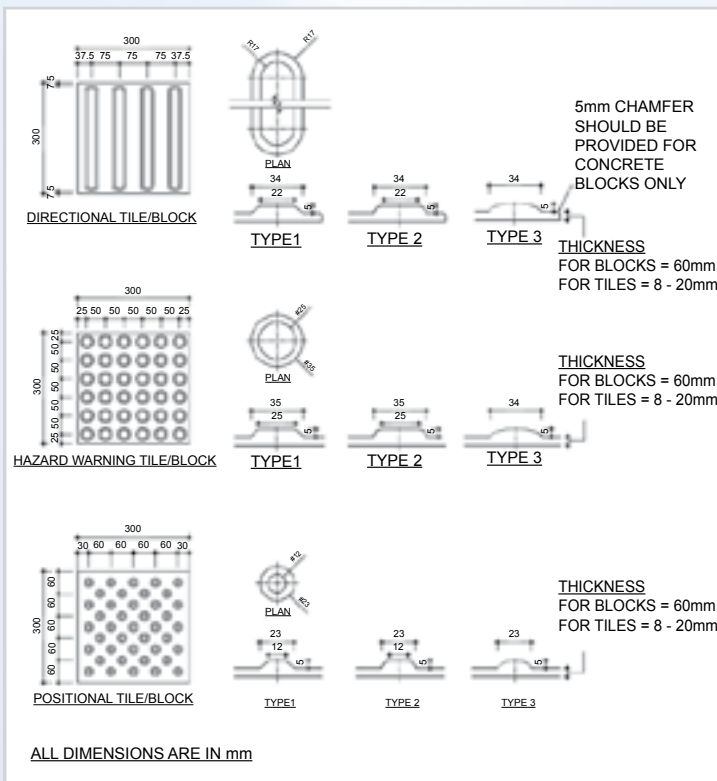

# Chapter -2 Ramps

A ramp is a sloping walkway leading from one level to another. Ramps of an appropriate design shall be provided at all changes in level other than those served by an accessible lift or accessible lifting mechanism accommodating the specific requirements of persons with a disability.

## Width

A ramp shall not be less than 1800 mm in width.

## Landing

A clear space of not less than ramp's width shall be provided at the head and foot of every ramp, i.e. door swing and alike shall not be allowed to swing onto the landing.

## Running Slope and Length

No ramp shall be steeper than 1 in 12 gradient.

- A kerb of at least 100 mm high or a rail 200 mm above ramp level shall be provided on both sides to prevent wheelchair from slipping over the edge.
- No appliances, fixtures and fittings shall project beyond 90 mm from the surface of any wall below a level of 2000 mm above the ramp level unless they are unavoidable, in which case they shall also be extended downwards to the ramp level or be guided by tactile flooring materials.
- The floor and wall along ramps shall be in contrasting colors.

## Design Considerations

1. Where there is a change in level, the provision of a ramp is an effective method to ensure largely independent accessibility for persons with a disability and the elderly. Interior ramp is preferred as a means of egress to stair as it accommodates a wider range of building user, including wheelchair user.

2. The more gradual the slope of the ramp (i.e. the less steep it is) the more easily persons can use it without assistance. Therefore, slope with the ratio of 1:20 (5%) to 1:15 (6.7%) is preferred. It can take much energy to get up ramp with steep gradient, which also makes speed control difficult when going down. Steep inclines can put a wheelchair in danger of tipping backwards or forwards as many users cannot lean or adjust their balance to accommodate gradient
3. A level resting space outside the swing of any door at the top of a ramp should be provided to avoid the possibility of 'roll-back' for wheelchair user when trying to open the door.
4. A ramp should have handrails on both sides so that it can be used in both directions by people with a mobility problem on one side such as may be the case for stroke sufferers.
5. A ramp that surmounts a major change in level has to be very long, and requires multiple ramp and landing combinations. In such circumstances, other design solutions should be considered.
6. A curved ramp is not a preferred design solution. Similarly a cross fall can put a wheelchair user at risk and may adversely affect steering, particularly on manually propelled chair.

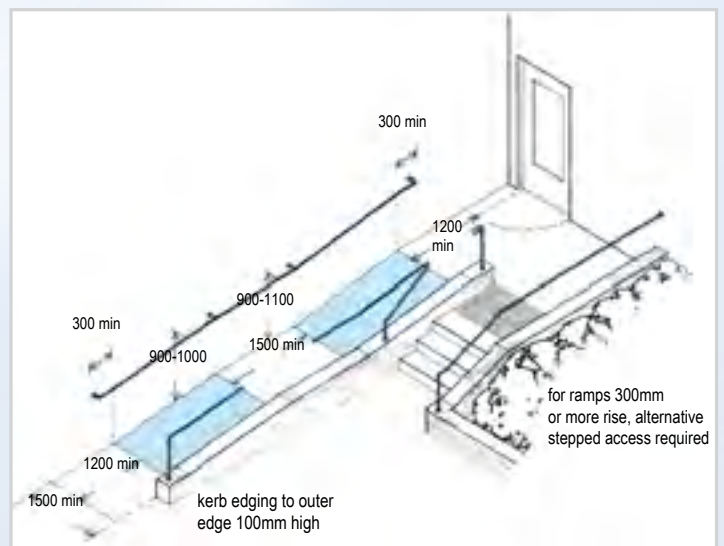

# Chapter -3 Dropped Kerbs

A dropped kerb is a ramp built on a footpath or pavement to accommodate the change in level towards vehicular areas. Dropped kerbs shall be of appropriate design and provided with adequate visual and tactile warning.

## General Provision

Changes in level at kerbs shall be by a dropped kerb. Dropped kerb shall be provided at pedestrian crossing and at each end of the footpath of a private street or access road. Kerb separating footpath or ramp from vehicular area shall also be a dropped kerb.

## Requirements

Dropped kerb shall be constructed as follows: -

1. Not less than 1200 mm in length and 1200 mm in width;
2. With a clearance of at least 800 mm long at the back of the footway;
3. Ramped at a gradient not steeper than 1:12;
4. With a level difference of not more than 15 mm with the vehicular areas;
5. Provided with a tactile warning strip at 300 mm from the vehicular areas;

And

6. Provided with a tactile warning strip of the nominal width of 600 mm at the ramp.

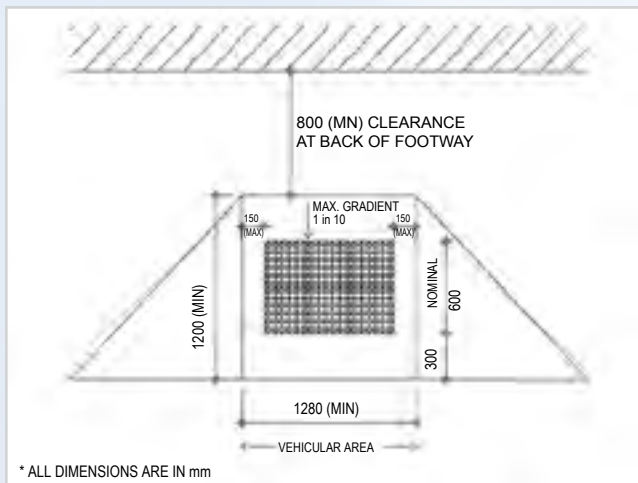

## Location

Dropped kerb shall be so located to enable users to have an unobstructed view of traffic approaching from any direction.

## Surface

Raised traction strips shall be avoided.

## Design Considerations

- The provision of a dropped kerb is to overcome potential hazard arising from change in level for persons with or without a disability.
- The tactile warning strip should be provided in order to notify the presence of traffic.
- The tactile warning strip should have luminous contrast for the elderly and persons with visual impairment.
- Dropped kerb should have slip-resistant surface. Raised traction strips should be avoided in order to reduce the hazard to everyone.

## Recommended Design Requirements

### Slip Resistance

Dropped kerb should have slip-resistant surface with a minimum “static coefficient of friction” of “Very Good” grading.

### Luminous Contrast

Tactile warning strip should have a minimum luminous contrast of 70% with the adjoining surfaces.

### Conjunction with Pedestrian Crossings

Dropped kerb should be provided where necessary and in conjunction with pedestrian crossings, which should include visible, audible and tactile crossing devices with traffic lights.

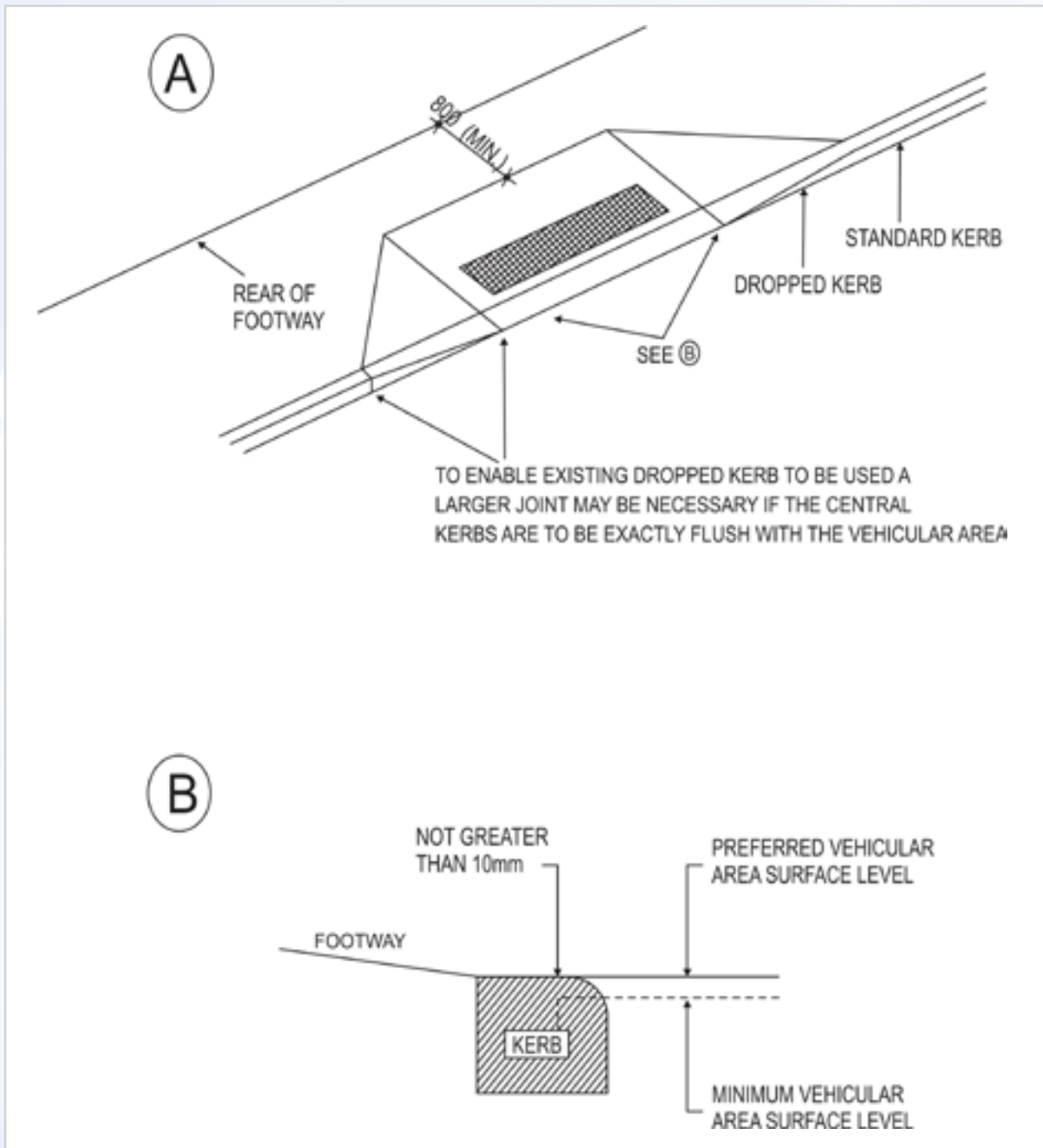

# Chapter -4 Staircases

Steps and staircases shall be intended as an alternative to lift access in buildings and shall be of adequate design to allow all persons, with or without a disability, to travel safely and independently.

## Dimension and Orientation

1. The required staircases and the main circulation staircase in common areas of a building shall be constructed with treads not less than 300 mm in width (measured at the centre of the flight) from the face of one riser to the face of the next riser and with risers not more than 150 mm in height;
2. The risers built with vertical or receding face not more than 15 mm from the vertical, without a projecting nosing;
3. It shall not have more than 11 steps in any flight without the introduction of a landing;
4. It shall be provided on both sides with properly fitted handrails.
5. It shall be provided with non-slip nosing in contrasting colour.

## Colour Contrast

Treads and walls of a staircase shall be in contrasting colours.

## Tactile Warning Strip

Tactile warning strips shall be provided at landings and at both the bottom and top ends of a staircase, regardless of the number of steps it comprises. For landings leading to a floor or those enclosed by wall, railing or balustrade, tactile warning strips of 300 mm in width shall be provided; for those leading to an open space or the entrance / exit of a building, the tactile warning strips shall be 600 mm in width. In this case, Braille and tactile information signs shall

be provided on the adjacent wall to indicate the presence of an opening. For a staircase with intermediate steps between two flights, the provision of tactile warning strips shall follow the arrangement in.

## Avoidance of Projection

No appliances, fixtures or fittings shall project beyond 90 mm from the surface of any wall in a staircase below a level of 2000 mm above the treads of the staircase unless they are unavoidable, in which case they shall also be extended downwards to the level of the treads.

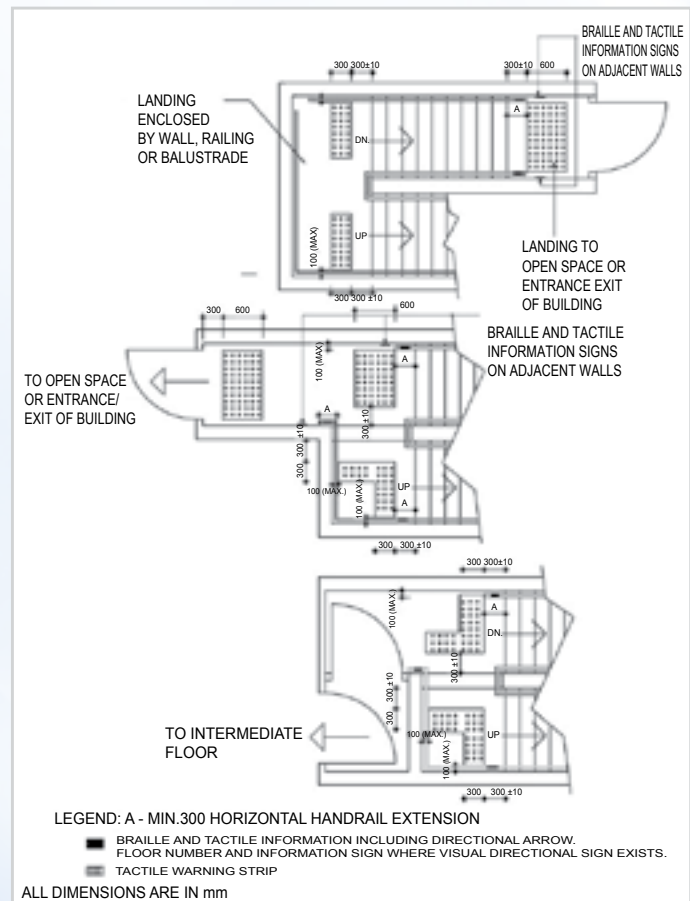

## Design Considerations

1. Where steps or stairs are in an accessible route, complementary ramps, lifts or escalators should be provided.

2. All steps should be uniform.
3. Circular stair and sloped landing should be avoided.
4. It is necessary to provide safe and well-dimensioned staircase for the comfort of all people, especially those with mobility problems.
5. When ascending a stair, people who wear calipers or who have stiffness in hip or knee joints are particularly at risk of trapping the toes of their shoes beneath projecting nosings.
6. Stair should be designed with more generous dimensions, e.g. wider tread, and shorter travel distance is recommended. Open risers should be avoided.
7. Unawareness of steps is dangerous to persons with visual impairment. Timely tactile or audible warning of change in level is therefore essential. Warning should be placed sufficiently in advance of any potential dangers.
8. The provision of Braille and high luminous contrast signs is recommended. For persons with visual impairment, high luminous contrast, larger font, more prominent and well-defined shape of sign/signage is recommended.
9. Despite the design requirements of tactile guide paths and tactile warning strips would help orientation for persons with visual impairment; they sometimes impose hazards to people with limited mobility, children and the elderly.

## Recommended Design Requirements

### Dimension and Orientation

1. For any internal stair with heavy circulation, riser should be reduced to 150 mm high and tread be increased to 300 mm wide for greater ease of use.
2. Individual flight should not exceed 1800 mm in height nor a total of 11 risers.
3. The top nosing of any flight should be built not less than 300 mm from the point at which the adjoining wall returns (see Figure 14).
4. Winder, spiral staircase and splayed step should be avoided.

### Luminous Contrast

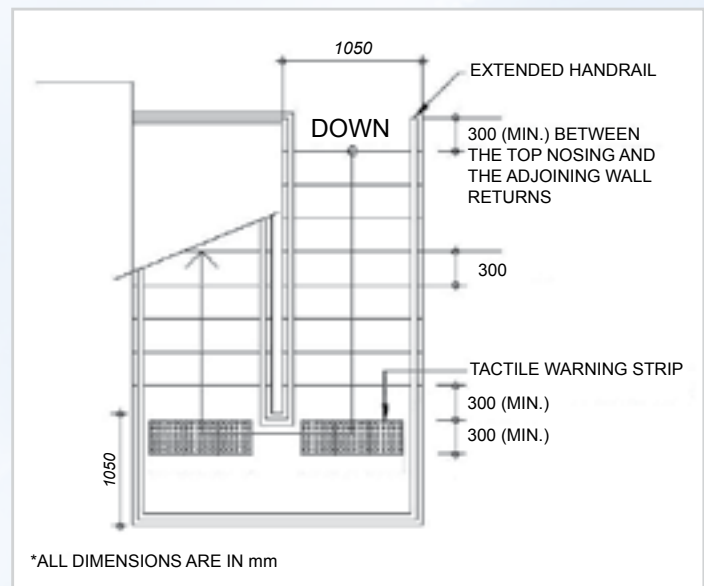

# Chapter -5 Handrails

Handrails provide support for everyone and are especially helpful for persons with a disability and the elderly to use staircases, to pull themselves up inclines, check themselves on declines and to assist them in moving within the building.

## Performance Objectives

Handrails shall be of the correct sizes, strengths and shapes and be conveniently located to provide secure hand-grips, and be capable of taking the entire weight of the persons using them.

## Dimension and Shape of Handrail

- Handrail to ramp and step shall be fixed not less than 35 mm and not more than 50 mm clear of wall and with a clear height of 70 mm from the top of the bracket to the top of the handrail.
- The top of handrail shall be at a height of not less than 850 mm and not more than 950 mm above any nosing, floor or landing.
- Handrail shall be tubular, not less than 40 mm and not greater than 50 mm in external diameter and in other shapes that can provide the user a grip similar to that specified in the case of tubular handrails.
- Handrail shall extend horizontally not less than 300 mm beyond the first and last nosing of every flight of steps or beyond the ends of a ramp and terminate into a closed end which shall turn down or return fully to end post or wall face and which shall not project into a route of travel.

## Loading

- Handrail shall be installed to resist a load of not less than 1.3 kN applied vertically or horizontally.
- Handrail shall not rotate within its fixing fittings.

## Braille and Tactile Information

- Braille and tactile information on directional arrow and floor number shall be provided on handrail on every floor at a designated location to facilitate persons with visual impairment.
- Where a directional sign exists on handrails, Braille and tactile information shall also be provided

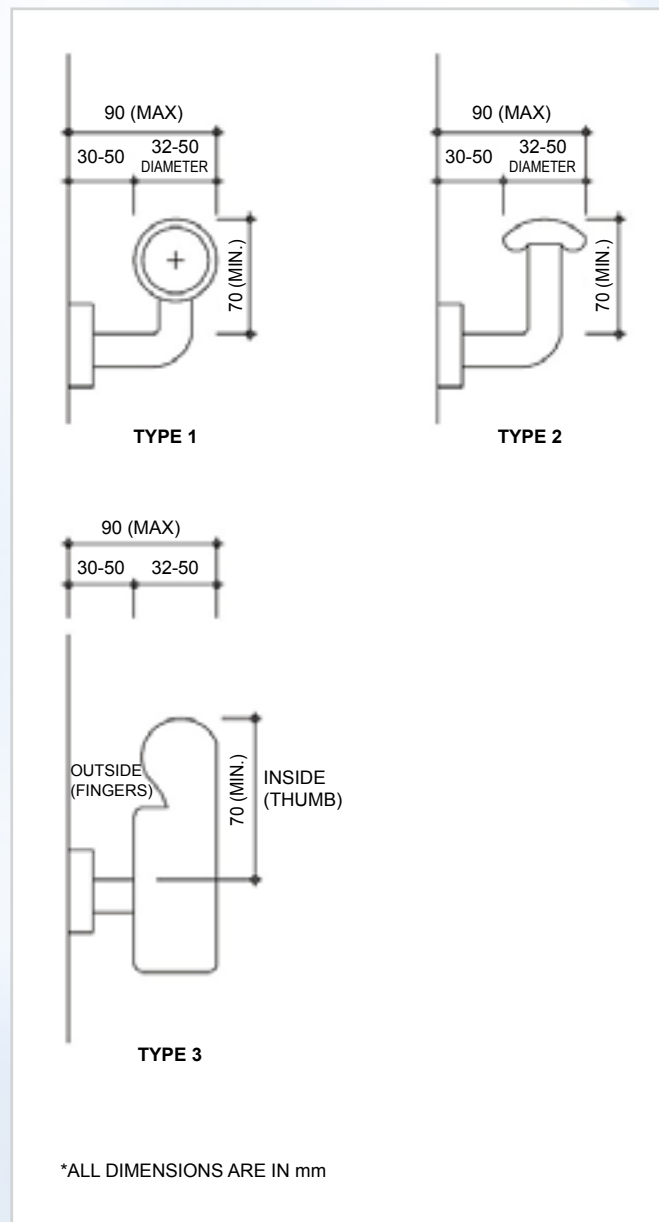



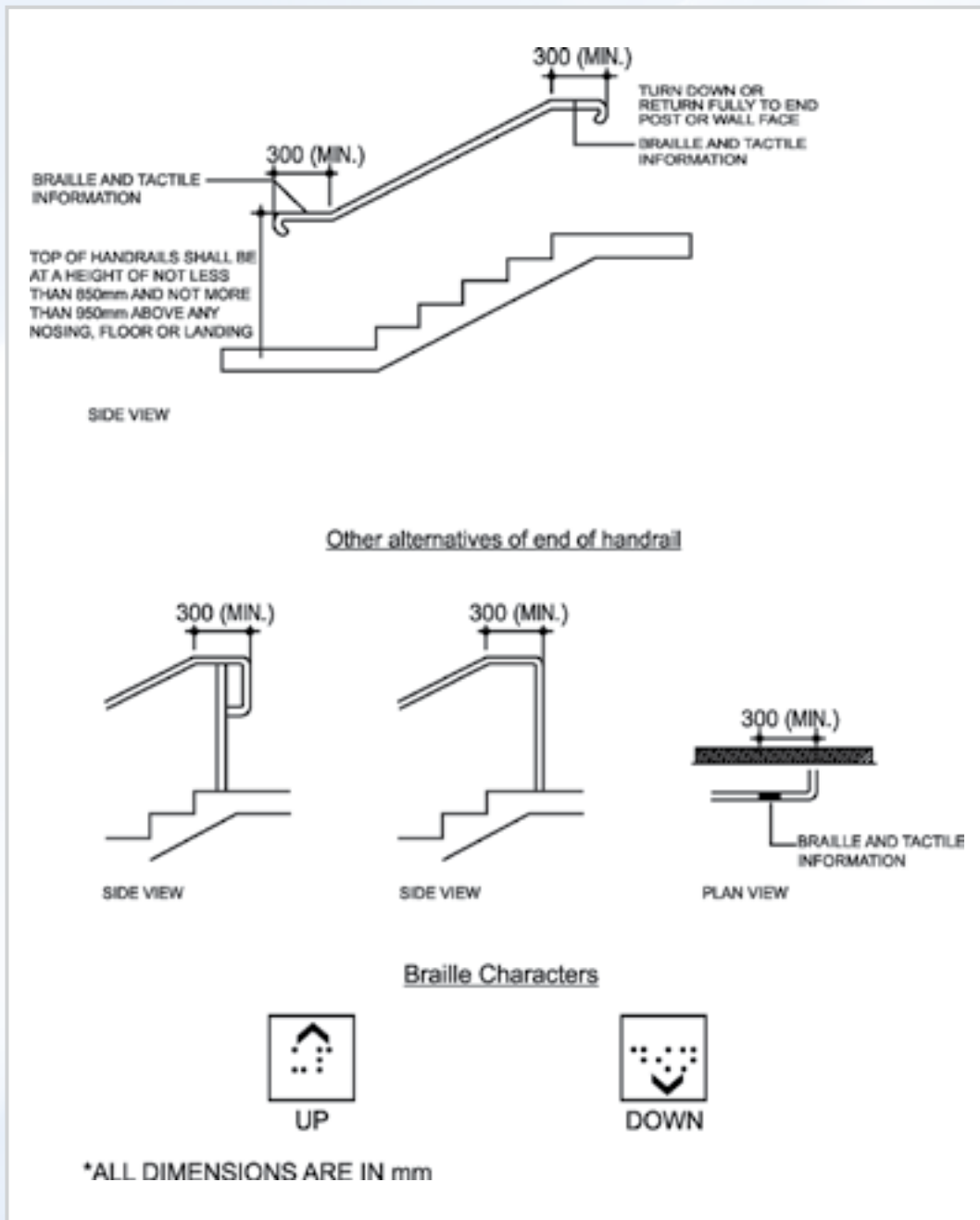

## Design Considerations

1. Handrail should be designed to provide easy, firm and comfortable grip to all users and should have no obstruction when people slide their hands along the handrail.
2. The installation level of the handrail and clearance dimensions should facilitate
3. a safer grip and prevent hand injuries especially for the elderly and persons with visual impairment.
3. Handrail finished in more noticeable colors with Braille and tactile information should facilitate self-help circulation of persons with visual impairment.

- The materials and shapes of handrail should be carefully designed to suit the elderly. In addition, handrail designed with different levels of grab bars should be recommended for different users' purposes. Handrail should be set at a height that is convenient for all users of the building and should extend safely beyond the top and bottom of a flight of steps, or a ramp, to give both stability and warning of the presence of a change in level.

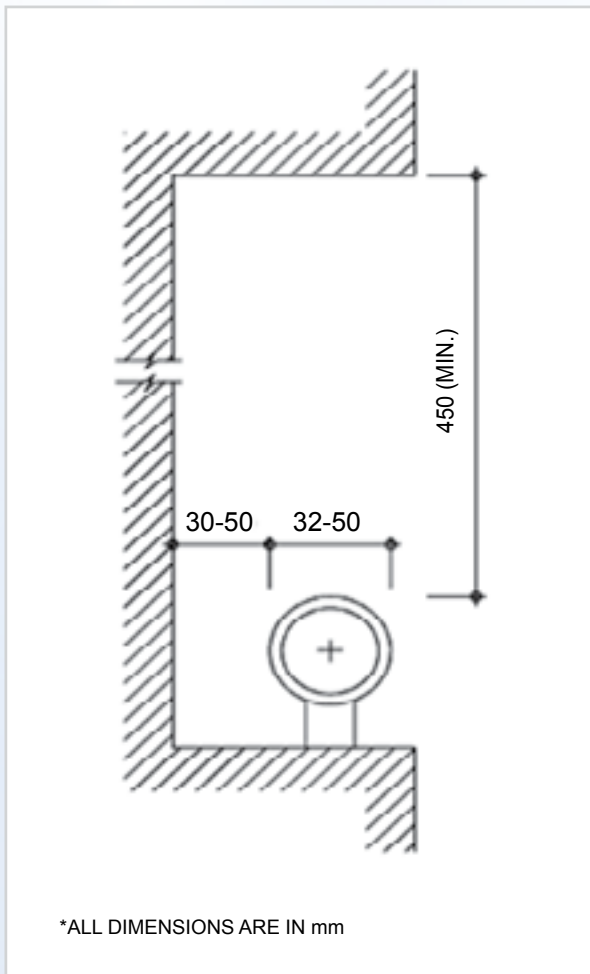

## Clear Space

- Where the wall has a rough surface, the clear space should be not less than 45 mm between the handrail and the wall.
- A recess containing a handrail should extend not less than 450 mm above the top of the handrail.

## Double Handrail

One more handrail should be provided at a height of not less than 700 mm and not more than 800 mm above any nosing, floor or landing for schools and places of public entertainment.

## Luminous Contrast

Handrail should have a minimum luminous contrast of 30% with the surrounding wall surfaces.

# Chapter -6 Corridor, Lobby & Pathways

Corridors are passages providing for internal circulation within a building. Lobbies provide interceptions at entries to staircases or lifts and connections to corridors where appropriate.

## Performance Objectives

Corridors, lobbies and paths shall be designed to an appropriate standard to allow all people to travel within a building safely and independently.

## Obligatory Design Requirements

### Maneuvering Space

1. Space shall be allowed for maneuvering wheelchairs in corridor, lobby, path and similar areas as follows:
2. Area shall have a clear width of not less than 1500 mm;
3. A space not less than 1500 mm x 1500 mm shall be provided within 3500 mm of every dead end.
4. Any lobby in a corridor shall have a length of not less than 1200 mm, excluding space for door swings;
5. A level area, extending not less than 1200 mm beyond the swings of the doors and not less than 1500 mm in width shall be provided on both sides of every entrance of a building; and this paragraph shall not apply to lobby which lead to staircase only.
6. For the purpose of this paragraph, "dead end" is a corridor, lobby or path where the means of exit for persons with a disability is in one direction only.

## Channel Covers

On footpath, cover to a channel shall be flush with the surface of the footpath. Any hole in such cover or between such covers shall have a dimension of not more than 20 mm.

## Gratings

Slot of gratings shall have a width of not more than 13 mm and shall not be parallel with pedestrian travel path.

## Protrusion

No appliances, fixtures and fittings shall project beyond 90 mm from the surface of any wall in corridors, paths and lobbies below a level of 2000 mm above the finished floor level unless they are unavoidable, in which case they shall also be extended downwards to the finished floor level or guided by tactile flooring materials.

## Grating Size and Orientation

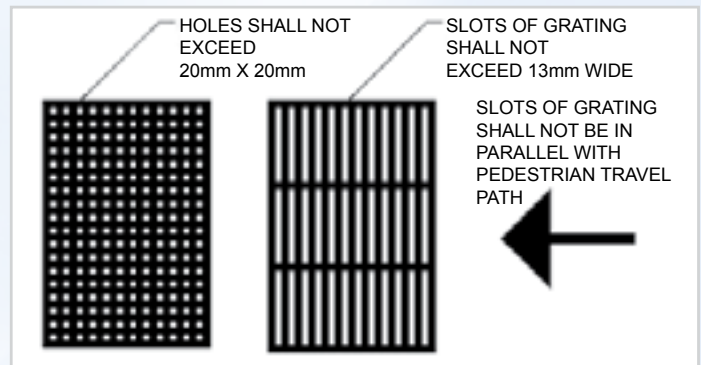

## Controlled Passage

For cashier counter, security device installed at shop entrance or turnstile controlled passage accessible to the public, each shall have at least one path of minimum 900 mm in width for the use by wheelchair users and clearly marked with international symbol of accessibility, unless an alternative passage adjacent to the controlled passage is provided.

## Headroom

Where the headroom is 2000 mm or less from the finished floor level, a warning guardrail or other barrier shall be provided for detection, having its leading edge at or below 680 mm above the finished floor level (see Figure 19).

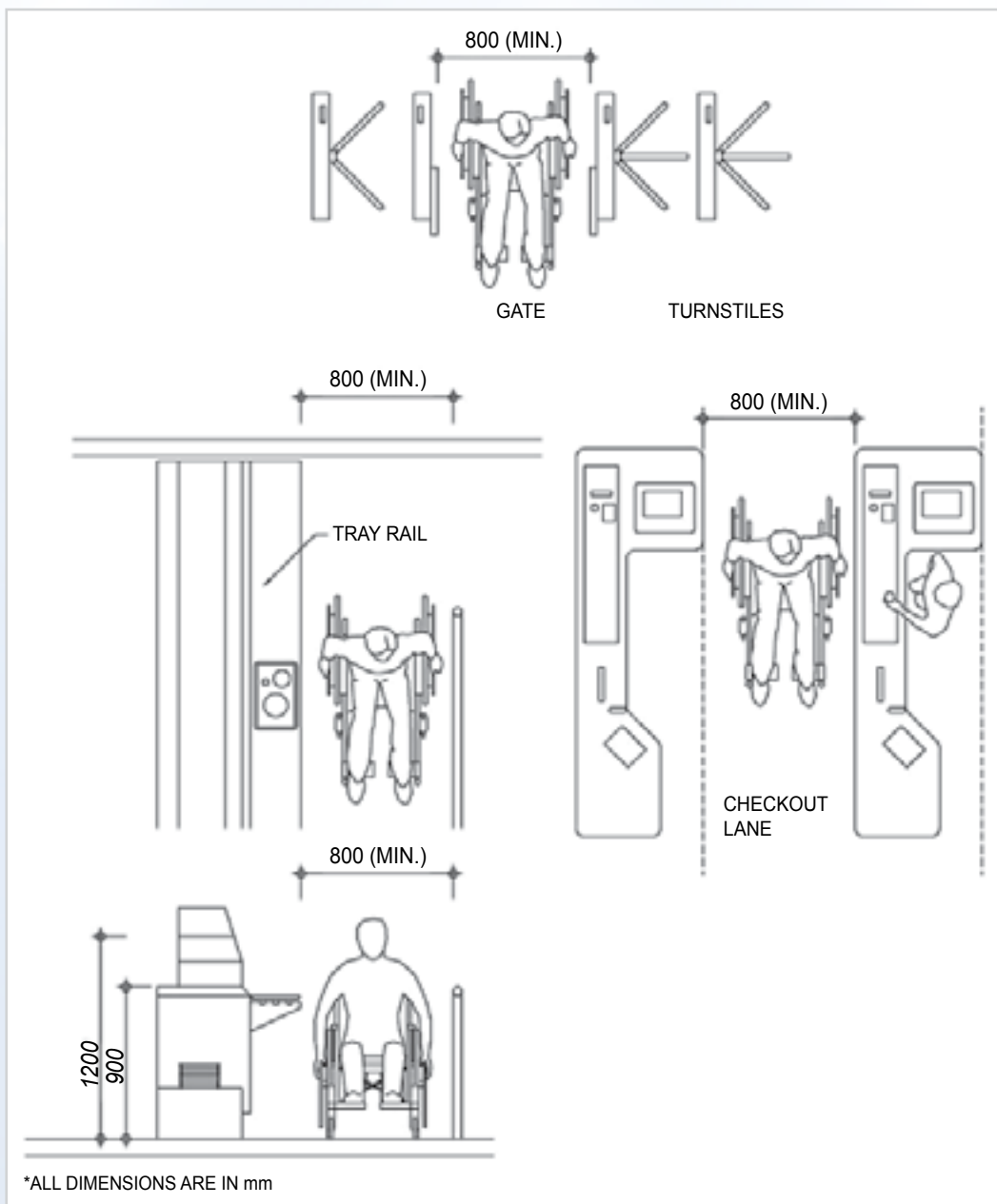
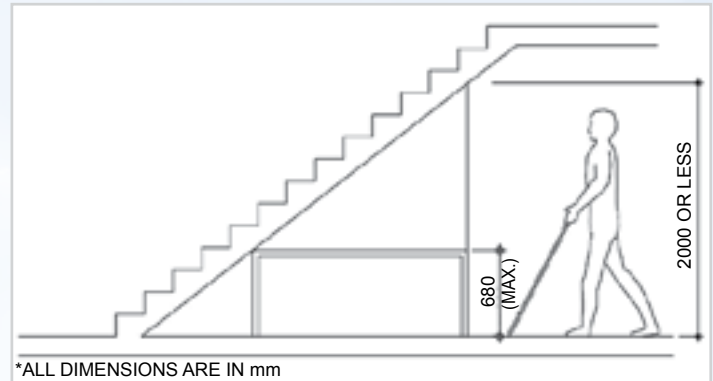

## Design Considerations

- Corridors, lobbies and paths should be designed to have appropriate dimensions to allow people using wheelchair or other forms of mobility aids to pass others on the access route.
- To facilitate the way finding for persons with visual impairment, surfaces and finishes with luminous contrast between the wall and the ceiling, and between the wall and the floor should be adopted. Appropriate lighting design with adequate illumination should also be considered.
- Adequate maneuvering space for wheelchair particularly in lobby and corridor of domestic building should be provided in order to facilitate the wheelchair users in passing through corridor especially when turning through 180° is required.
- Protruding object can be extremely hazardous to the persons with visual impairment as well as the general public. Examples of protruding obstruction are sign, drinking fountain, fire extinguisher, telephone enclosure, and underside of stairway or escalator, etc. Protruding object should be recessed into the wall as far as possible.

## Recommended Design Requirements

### Width

Path width should be more than 1200 mm to enable a wheelchair user to pass anyone who is on the same path or preferably at least 1500 mm to allow two wheelchairs to pass. At right angle turns, inside corner should be splayed or rounded to at least 300 mm radius.

### Surface

- All corridors should have slip-resistant surfaces with a “static coefficient of friction” of “Good” grading.

- Surface paved with loose gravel or stone is hazardous and should be avoided.
- Hazards on floor, caused by unnecessary projection or by unexpected change in level should be avoided.

## Luminous Contrast

A minimum luminous contrast of 30% should clearly define between wall, floor and door surfaces.

## Protruding Objects

- The protruding object should not reduce the statutory required clear width and height of access and maneuvering space.
- Protruding object should include but not limited to sign, telephone enclosure, drinking fountain, fire extinguisher, underside of stairway or escalator.
- Where it is reasonable to anticipate visit of persons with visual impairment, protruding object should be avoided at pedestrian areas include walkway, hall, corridor, aisle, lobby, mall and all areas open to the public.

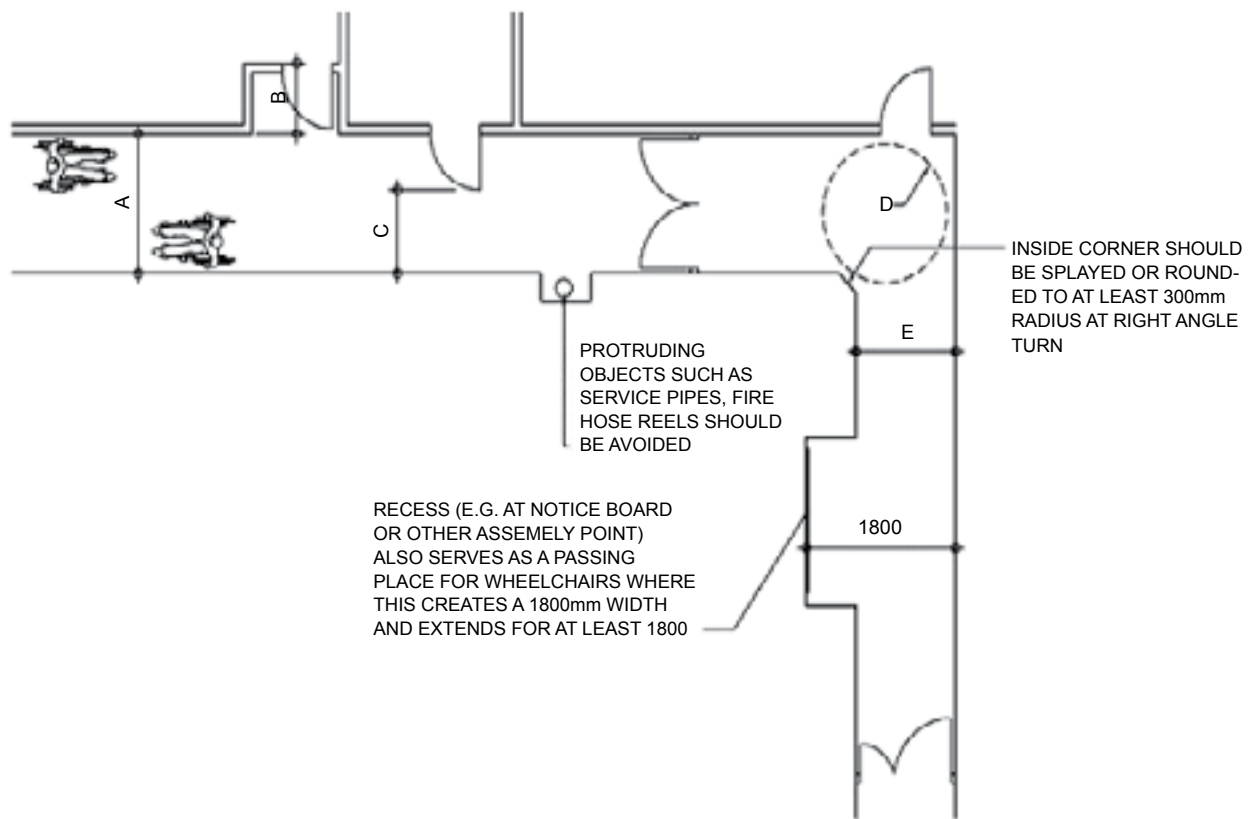

- A. A CLEAR WIDTH OF 1500mm WILL ALLOW TWO WHEELCHAIR USERS TO PASS EACH OTHER.
- B. DEPTH OF RECESS SHOULD NOT BE LESS THAN THE WIDTH OF THE DOOR LEAF.
- C. 900mm CLEAR SPACE WHERE DOORS OPEN INTO A CORRIDOR.
- D. TURNING CIRCLE OF 1500mm DIAMETER AT A CORRIDOR JUNCTION ACTS AS A PASSING PLACE AND ALLOWS A WHEELCHAIR USER TO TURN AND RETURN IN THE OTHER DIRECTION.
- E. A CLEAR WIDTH OF CORRIDOR SHOULD NOT BE LESS THAN 1200mm.

\*ALL DIMENSIONS ARE IN mm

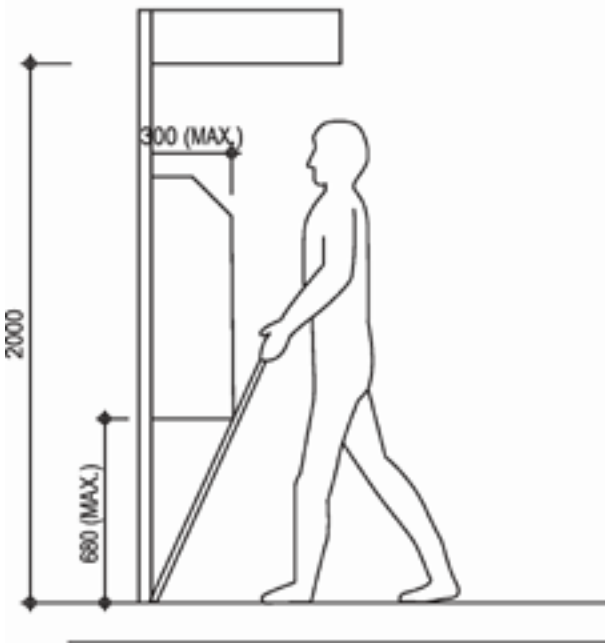
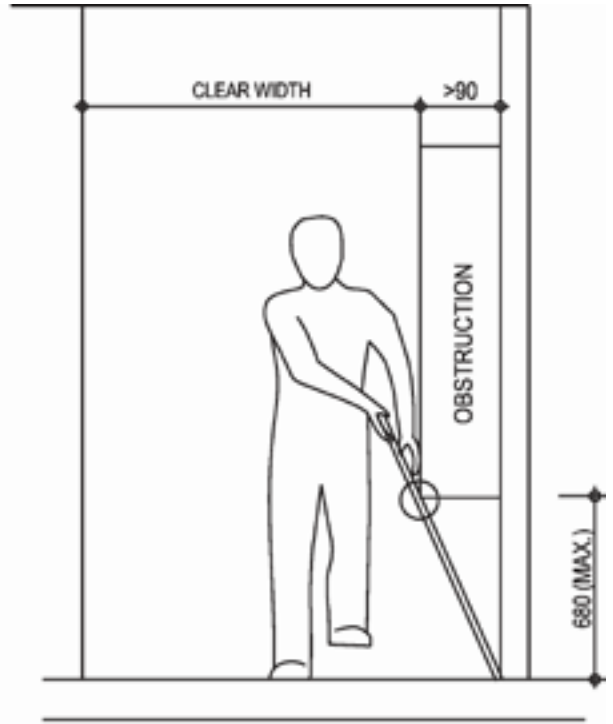
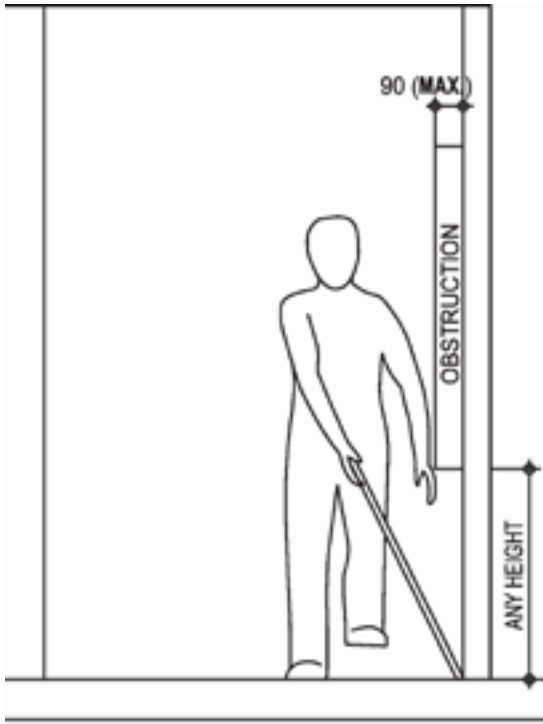

\*ALL DIMENSIONS ARE IN mm

# Chapter -7 Doors

Doors and doorways shall be designed to enable all people especially wheelchair user to enter and leave any room unaided or without undue difficulties.

## Width of Doors

Door, including one leaf of a pair of double doors, shall have a clear width of not less than 900 mm between the open door and opposite jamb or the other leaf.

## Unobstructed Area

- The unobstructed area adjacent to the door handle on the leading face of a single door shall not be less than 330 mm in width.
- Door, if less than 330 mm from the corner of a room, shall swing from the side nearer to hat corner.

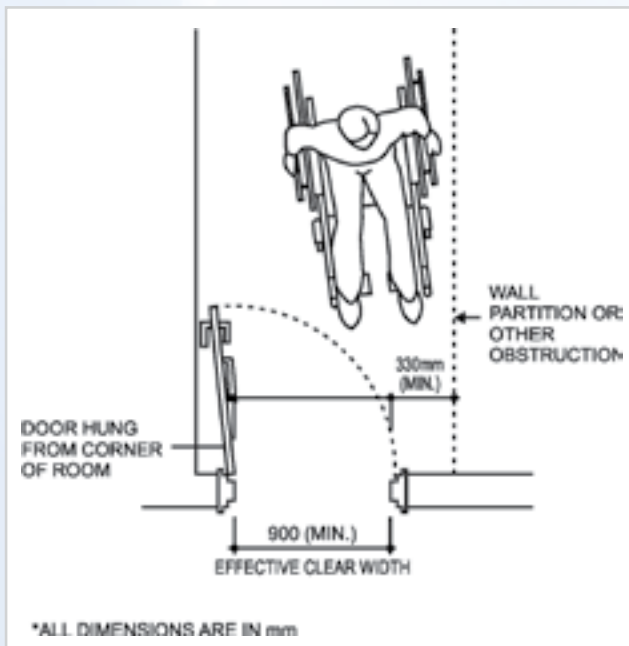

## Double-action Self-closing Doors

Double-action self-closing door shall have a check mechanism to prevent the door swinging beyond the closed position and a transparent vision-panel with a bottom edge not more than

1000 mm above the floor and the top edge not less than 1500 mm above the finished floor level.

## Handles

Door handle shall not be less than 950 mm and not more than 1050 mm above the finished floor level, measured from the top surface of the grip.

## Door Thresholds

Door threshold shall not exceed 20 mm in height and shall be beveled to facilitate passage of wheelchairs.

## Door Closing Devices

Door closing devices shall be designed to allow exterior and interior doors to be opened with horizontal force of not more than 30 N and 22 N respectively. Door required to have fire resistance period installed along accessible routes shall be opened with horizontal force of not more than 30 N. Closer for interior door shall have a closing period of at least 3 seconds measured from an open position of 70° to a point 75 mm from the closed position measured from the leading edge of the door. Door closing devices include door closer, spring hinge and floor hinge.

## Frameless Glass Doors

If frameless glass door is used, it shall be prominently marked so as to make it visible. The marking shall be placed across on the glass door such that at least a portion of the marking is placed between 900 mm and 1500 mm above the finished floor. The colour marking shall also be provided to glass panel adjacent to the glass door.



## Automatic Main Entrance Doors

Automatic door shall be provided to one of the main entrances, which is commonly used by the public, of sports stadium, town hall, civic centre, theatre, museum, public library, shopping complex, sports complex, public swimming pool complex, office building, hotel and hospital.

## Design Considerations

- Door may be manually operated without powered assistance, or power operated under manual or automatic control. An automatically operated sliding door is a preferred solution for most people as it avoids the risks associated with automatic swing door and its use can make it possible to reduce the length of entrance lobbies.
- A door fitted with a self-closing device to stand against wind force is difficult to be openable by many people, particularly those who are wheelchair users or who have limited strength. Where closing devices are needed for fire control, the use of electrically powered hold open devices or swing-free closing devices is appropriate.
- All doors should be wide enough to allow unrestricted passage for different users, including wheelchair users, people carrying luggage and parents with baby carriages and small children.
- Sufficient space alongside the leading edge of a door should be provided to enable a wheelchair user to reach and grip the door handle, then open the door without releasing hold on the handle and without the wheelchair footrest colliding with the return wall.
- The presence of door, whether opened or closed, should be apparent to persons with visual impairment through the careful

choice of colour and materials for the door and its surroundings. Provision of marking on glass doors would help persons with visual impairment to distinguish obstacles and passage as well as for public to avoid collision.

## External Doors

External door should be single-action and open outwards to obviate high tension in spring closers in sustaining wind pressure.

## Latched Doors

Where door is latched, lever-type handle should be used.

## Kick-plates

All doors which allow the passage of wheelchairs should have kick-plates of not less than 200 mm high fitted on the face which swings away.

## Automatic Door Openers

Automatic door opener should be provided on the main entrance door of buildings and should:-

- Remain open for a minimum of 5 seconds;
- Have a guardrail where it opens into a route of travel.
- Have a sign showing automatic door.
- Be located outside of the door swing.
- Sliding automatic door with overhead sensor operating device or manual Large button control should be provided.

## **Vision Panels**

Transparent vision-panel should be provided to door in between accessible path. The vision-panel should be installed with bottom edge not more than 1000 mm and top edge not less than 1500 mm above the finished floor level.

## **Glass Doors**

The leading edge of glass door should be marked to indicate glass.

## **Luminous Contrast**

Door handle of manually operated doors and control switch or button of door with powered open devices should have a minimum luminous contrast of 30% with the background finishes.

# Chapter -8 Toilets

This Chapter explains the requirements to enable persons with a disability, including wheelchair users to use the facilities provided in a toilet independently as far as possible.

Sufficient, properly designed and located toilet and W.C. cubicles shall be available for use by everybody including people of either sex, people with babies and small children, persons with a disability, wheelchair users and the elderly and elderly with frailty, etc. with or without any assistance from others.

Space requirements are set to enable a wheelchair user to maneuver into position for frontal, side or diagonal transfer to and from the W.C. seat.

## Obligatory Design Requirements

### Provision of Accessible W.C. Cubicle

There shall be at least one accessible W.C. cubicle on a floor, or in that part of a floor designed for access by the persons with a disability.

### Location of Accessible W.C. Cubicle

W.C. cubicles shall be accessible –

- Directly from a public corridor; and
- Where situated within a toilet containing other W.C. cubicles, through a clear space not less than 1500 mm x 1500 mm immediately in front of the compartment to allow maneuverability or by direct approach where no turning of the wheelchair is necessary.

### Design of Accessible Toilet

The accessible Toilet cubicle shall not be less than 2200 mm x 1750 mm in area and the clear maneuvering space within the cubicle shall not

be less than 1500 mm x 1500 mm measured at 350 mm above finished floor level and the cubicle shall have in it a water closet at a height not less than 380 mm and not more than 450 mm, measured to the top of the toilet seat. Water closets shall be equipped with a back support such as a seat lid and seats shall not be spring-actuated.

### Flushing Controls

Flushing control shall be mounted on the wide side of the cubicle at a height between 600 mm to 1050 mm above the finished floor level and shall be hand-operated or automatic. Hand-operated controls shall be capable of being operated with one hand and shall not require tight grasping, pinching or twisting of the wrist. The force required shall not be greater than 22 N.

### Wash Basins

The toilet shall be provided with a wash basin mounted with the rim not higher than 750 mm above the finished floor level. A clearance of 550 mm shall be maintained from the finished floor level to the bottom of the apron. Tap for wash basin shall be automatic or of lever control type without spring loading. Tap shall not require tight grasping, pinching or twisting of the wrist. The operating force required shall not be greater than 22 N.

### Toilet / Cubicle Doors

Door shall be installed with push-type or lever-type handles and capable of being easily opened/closed by one hand. Any door fastening shall be capable of being released from the outside in the event of an emergency. No coin box shall be affixed to the door of the cubicle.

## Grab Rails

- There shall be at least two grab rails which shall not be less than 35 mm and not more than 500 mm in external diameter and shall be fixed on the wall leaving a grip space of not less than 30 mm clear of the mounting wall. The two grab rails constructed in one continuous piece is acceptable.
- The length of grab rail shall not be less than 600 mm. There shall be one grab rail fixed on each of both the inner and outer surfaces of the cubicle door; which shall not be less than 32 mm and not more than 40 mm in external diameter.
- The grab rail shall have a grip space of not less than 30 mm clear of each door surface.
- There shall be one folding grab rail on the wide side of the cubicle adjacent to the water closet at a height between 725mm to 750mm above the finished floor level when lowered from the wall.
- Simple instructions in English, Hindi and Braille on how to unfold the rail should be affixed to the wall. The grab rail, folding grab rail and wash basin shall be capable of carrying a static load of 150 kg.
- The grab rail shall not rotate within its fixing fittings.

## Urinals

If more than one urinal is provided, at least one urinal shall

- Have a clear leveled space of not less than 800 mm wide x 1500 mm deep in front
- Be wall hung urinal with a front rim not higher than 400 mm, and have vertical grab rails of not less than 35 mm and not more than 50mm in external diameter and of 600 mm length on both sides at a height of 1200 mm above the finished floor level for use by persons with ambulant disabilities.

## Emergency Call Bell

An emergency call bell shall be provided in an accessible W.C. cubicle. The push button of the emergency call bell shall be appropriately located and conveniently accessible to all users. The emergency call bell when activated shall emit audible or visible alarm signal which shall be readily noticeable for summoning assistance for the person in the accessible toilet. The alarm shall be installed outside the toilet or a buzzer shall be fitted in the caretaker's office.

## Push Button for Emergency Call Bell

An emergency call bell shall be equipped with a weatherproof push button for activating the alarm. The push button shall be installed below the vertical grab rail inside the W.C. cubicle adjacent to the water closet at a height between 600mm to 650mm above the finished floor level. A notice "Emergency Call" in English, Hindi and Braille shall be fitted next to the emergency pushbutton.

## Design Considerations

- A push button should be easily operated and be provided in any individual accessible toilet compartment or a water closet cubicle designed for the persons with a disability to summon assistance at seated position or on the floor when the person has fallen accidentally.
- The call button, sometimes equipped with a pull cord of a length between 700 mm to 750 mm should be suitably positioned and reachable not more than 300 mm from floor level. In addition to a position outside the compartment or cubicle, the emergency alarm should be connected to a 24-hours manned caretaker's office.

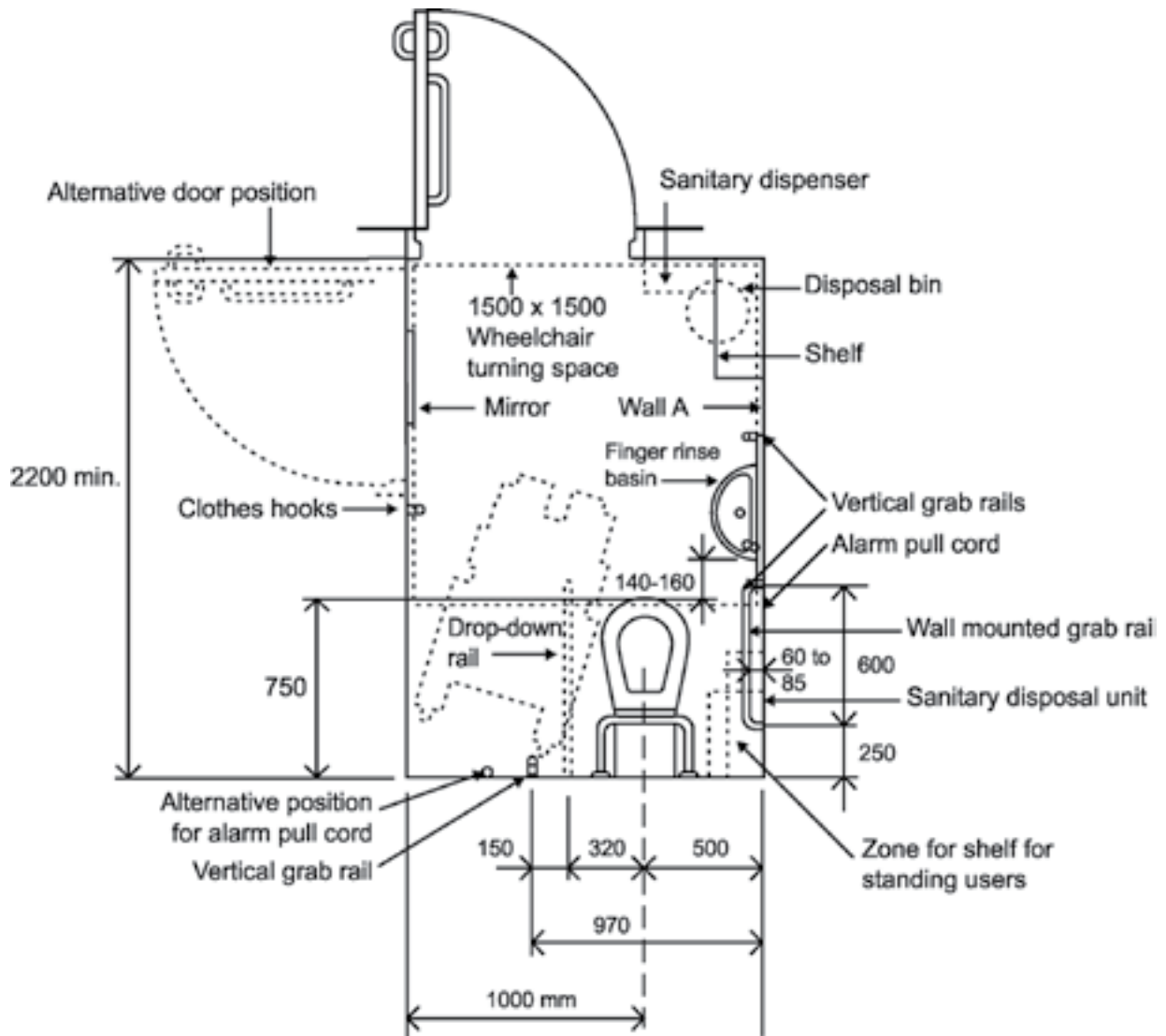

# Chapter -9 Bathrooms & Shower Compartments

The accessible bathrooms and shower compartments shall be so designed and equipped with sanitary fittings and installations to allow persons with a disability and the elderly to use them without assistance from others.

## Obligatory Design Requirements

### Bathtubs

- There shall be a clear floor space of not less than 1500mm x 800 mm in front of the bathtub.
- The bathtub shall be provided with a seat of not less than 250 mm in width.
- The bathtub shall have a maximum height of 380 mm.

### Grab Rails for Bathtub

Grab rails shall: -

- Not rotate within their fixing fittings;
- Have a diameter between 35 mm – 50 mm and have a grip space of not less than 30 mm clear from the wall;
- Be at least 900 mm long, installed horizontally or slanting at an angle not exceeding 20 degrees along the length of the bathtub and at a height between 150 mm to 300 mm above the rim of the bathtub.
- Be at least 600 mm long, installed vertically at the plug end of the bathtub adjacent to the clear floor space with the lower end 150 mm to 300 mm above the rim of the bathtub.

### Taps and Controls of Bathtub

Taps and other controls shall: -

- Have lever type handles at least 75mm long from the centre of
- Rotation to the handle tip;
- Be installed at the plug end of the bathtub
- Be not more than 450 mm above the rim of the bathtub.

### Shower Heads

Shower heads shall: -

- Be of the hand-held type;
- Be provided with a hose not less than 1500 mm in length; and
- Be provided with a wall mounting bracket to allow use in a fixed position.

Where shower heads are mounted on a vertical bar, the bar shall:-

- Have a minimum length of 500 mm with the lower end not less than 450 mm above the finished floor level;
- Be installed so as not to obstruct the use of grab rails referred to in paragraph 57; and
- Be so mounted to be able to carry a static load of 150kg in case they are mistakenly used as a grab rail.

### Shower Compartments

Shower compartments shall have internal dimensions of not less than 1500 mm x 900 mm. The minimum clear floor space in front of the shower entrance shall be 1500 mm x 900 mm with the 1500 mm dimension parallel to the shower entrance.

### Grab Rails for Shower Compartments

Grab rails for shower compartments shall: -

- Be L-shaped or two bars arranged in L-shaped configuration and
- Not be less than 750 mm by 900 mm in length;
- Be installed at a height between 700 mm and 800 mm from the shower floor; and
- Be capable of carrying a static load of 150kg.

## Thresholds

Thresholds for shower compartments shall: -

- Not be more than 13 mm high; and
- Have beveled edges.

## Shower Seats

The shower seats shall: -

- Have a rounded edge and be self-draining ;
- Be installed on the wall next to the taps and controls;
- Not be less than 550 mm in width and 400 mm in depth; and
- Be installed at a height between 430 mm and 480 mm from the
- Top of the seat to the finished floor level.

## Design Considerations

Wheelchair users generally require larger space for access to the bathrooms. A proportion of guest rooms should be designed to accommodate the need of wheelchair users.

## Recommended Design Requirements

Taps and other controls should be installed between the centre line and the outer edge of the bathtub.

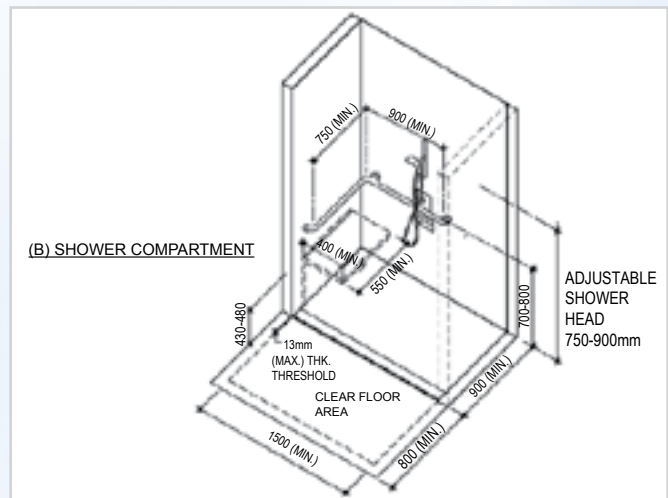
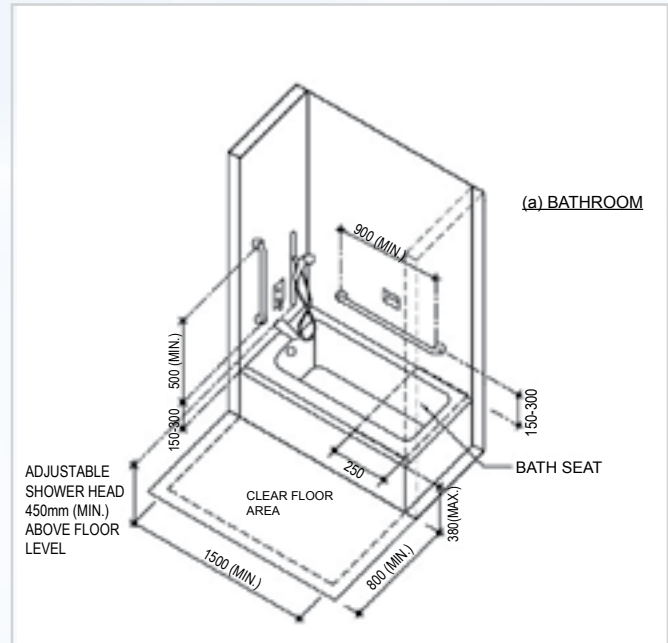

# Chapter -10 Signage

It is essential that suitable signs are placed at prominent and required positions inside and outside a building to indicate clearly the exact locations of facilities that are available for use by persons with a disability. To design an effective signage system, the needs of different types of users in a building and the complexity of the building layout must be considered.

## Performance Objectives

Signs shall give clear directions, information and instructions for the users of the building.

## The International Symbol of Accessibility

The international symbol of accessibility shall be the wheelchair figure in white on a blue background and is to be provided at conspicuous location for the purposes of identifying/ advertising /signifying:

- Accessible entrance to the building;
- Accessible exit from the building;
- Reserved car parking facilities for persons with a disability;
- The location of toilets for persons with a disability;
- Usable vertical circulation facilities;
- Usable cloakroom facilities; and
- The availability of special services of information / service counter and telephone in the building.

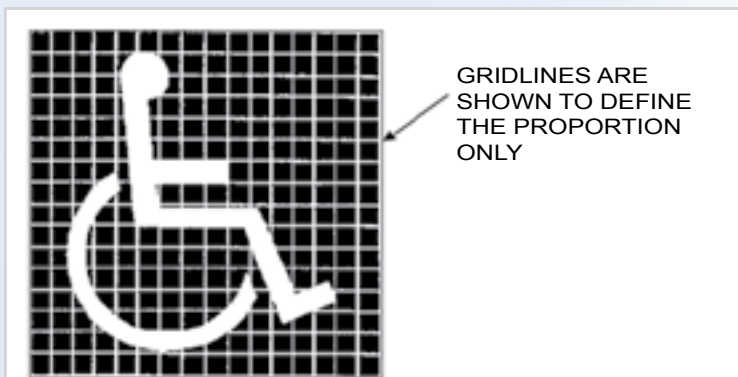

## Directional Signs

Directional arrows and visual information shall be provided at conspicuous location in conjunction with the international symbol for accessibility to guide persons with a disability to the exact locations of the accessible facilities.

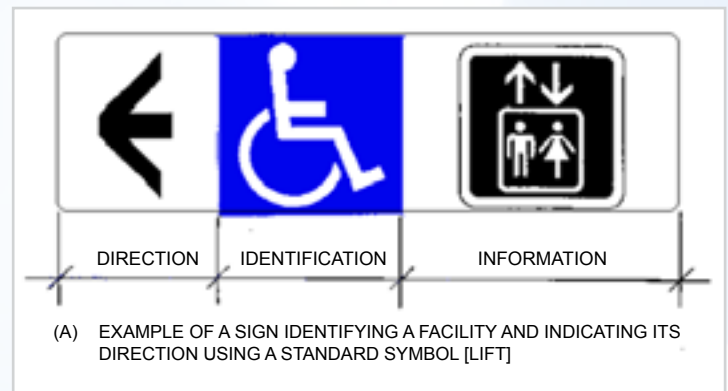

## Size

The height of signs shall be not less than the following :

- 60 mm for doors
- 110 mm for corridors
- 200 mm for external use

## Sign for Persons with Hearing Impairment

International symbol of access for hearing loss as shown in Figure shall be provided if there is an assistive listening system provided for persons with hearing impairment.

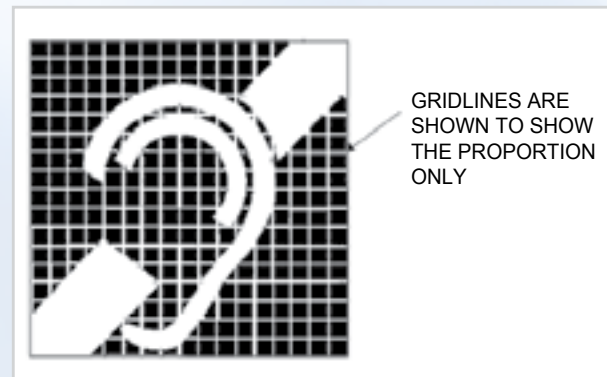



## Braille and Tactile Sign

Braille and tactile sign shall be installed on adjacent wall or door of public toilet to indicate whether the toilet is for male, female or unisex. The sign shall be placed at 900 mm to 1500 mm above the finished floor level. Specification of Braille cells is shown in Figure 31.

If there is no door, the sign shall be provided on the wall in front of the toilets.

A Braille and tactile fire exit map shall be provided directly above the call button of the accessible lift in the lobby of the accessible lift in a building if a fire exit map for the use of the public is provided. The map shall be placed at 800 mm to 1200 mm above the finished floor level.

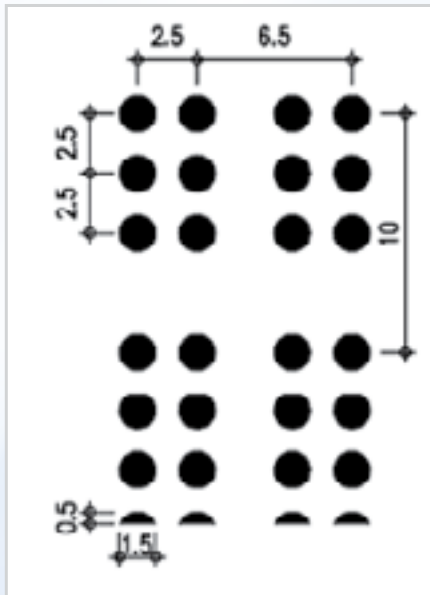

Dot Spacing :	2.5mm	Character Spacing :	6.5mm
Dot Height :	0.5mm	Line Spacing:	10.0mm
Dot base diameter:	1.5mm		

## Special Design Requirements to assist persons with visual or hearing impairment

- If a floor plan for the use of the public is provided, Braille and tactile floor plan showing the main entrance, public toilet and major common facilities shall be provided in a place in that building which is prominent to persons with visual impairment.
- Tactile guide path shall be installed from a point of access at the lot boundary to the main entrance of the building and from the main entrance to lift zone, the nearest accessible toilet, public information/service counter, Braille and tactile floor plan and staircase.
- If visual display board (such as LED) is provided, it shall be able to display the essence of the information broadcasted by the public address system in the building.

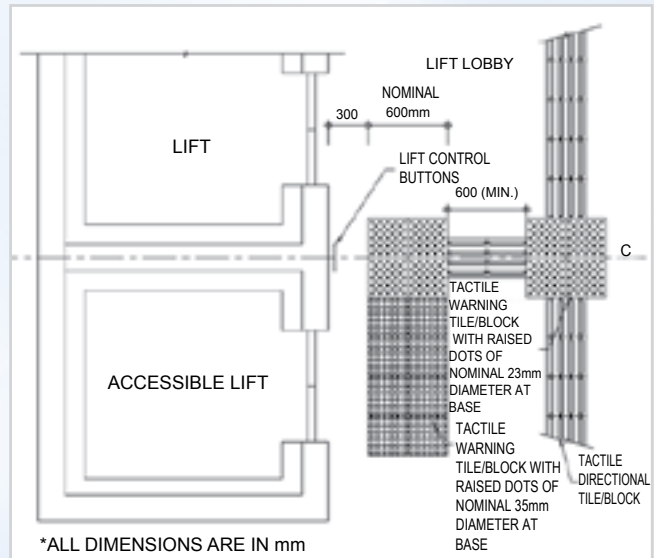

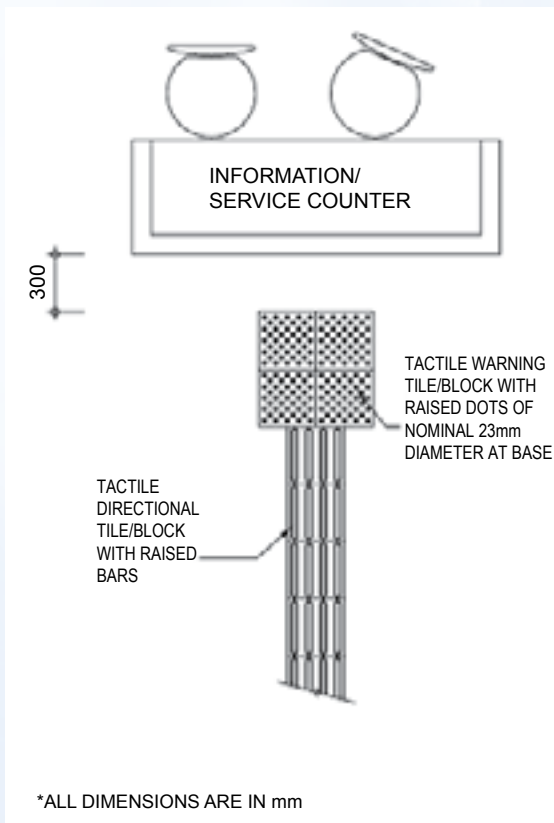

## Design Considerations

- Signs should be clear and easy to read and understand in order to assist persons with intellectual, cognitive and sensory disabilities.
- International symbols are to be used for purpose of standardization and apprehension by all persons with a disability residing in Hong Kong or visiting from overseas.
- Prominent signs with high color and luminous contrasts as well as special shapes are recommended to be used for the elderly.
- Safety for persons with visual impairment should be considered.
- Information such as distance to the destination, name of building etc. should be conveyed to the persons with visual impairment. The suggested provisions are

voice message, Braille and signs with high luminous contrast.

- To account for persons with visual impairment, larger fonts, more prominent and well-defined shapes of signs are recommended.
- Tactile guide paths should be provided for persons with visual impairment from the main entrance to lift zone, public information/service counter, Braille and tactile floor plan, and staircase/escalator provided with audible signals. Braille and tactile floor plan showing the locations of major common facilities should be provided in a location in that building which is conspicuous to persons with visual impairment.

## Location

Sign should be erected to indicate clearly the locations of accessible routes through the building.

## Luminous Contrast

Luminous contrast of not less than 70% should be provided to differentiate the international symbol of accessibility from the background, either light-on-dark or dark-on-light. The commonly employed colours are white for the wheelchair figure and blue for the background.

## Lettering and Colour

- Lettering should be plain and legible, e.g. Arial (medium) using lower case letters except for initial capitals.
- Corners of sign should be rounded.
- Sign should be in raised characters.
- The system of sign used should be clear and consistent.

## Braille and Tactile Sign / Audible Sign

- Braille and tactile building name and address (i.e., street name with number) or a device which when activated will provide the same information in audible form should be provided on both sides of the building entrance at a height of between 900 mm and 1500 mm above the finished floor level.
- If public address system is provided to convey information to the public in a building, then a means of conveying the same or equivalent information to persons with hearing impairment should also be provided.

- If a floor plan for the use of the public is provided, Braille and tactile floor plan with audible device indicating the main entrance, public toilet and major common facilities should be provided in a place in that building which is conspicuous to persons with visual impairment.

## Visual Sign

Visual display board (such as LED) should be provided in public waiting areas and where there is an announcer installed to regularly convey information to the people inside. The visual display board should be able to display the essence of the information so announced.



# Chapter -11 Public Information or Reception Counters

Information, service or reception Counters refer to provisions for assistance in a building where the public or a section of the public is likely to approach to seek services or information.

## Provision of Public Information or Service Counters

Public information/service counters shall be provided to various categories of buildings as specified in NBC 2005.

There shall be at least one public information/service counter built with a portion not higher than 750mm above the finished floor level and not less than 900 mm wide to assist wheelchair users

There shall be at least one public information/service counter provided with an assistive listening system where the background is noisy or counters are provided with screen.

## Design of Counter

Where public information/service counters are provided, they shall be accessible and easily identifiable from a building entrance by all persons with or without a disability.

Leg space of a depth between 400 mm – 600 mm and a height of not less than 680 mm above finished floor level shall be provided.

## Design Considerations

- The approach to the counter should be direct, clear and unobstructed.
- Signs associated with counters should be located and visible to wheelchair users.
- Counters should be located away from the entrance if disturbance of noise from external is anticipated.

- Provision of permanent or temporary control barriers for queuing should allow space for maneuvering of wheelchairs.
- For the convenience of the people using sticks, a recess should be provided to the information/service counter for them to place the assistive tools.

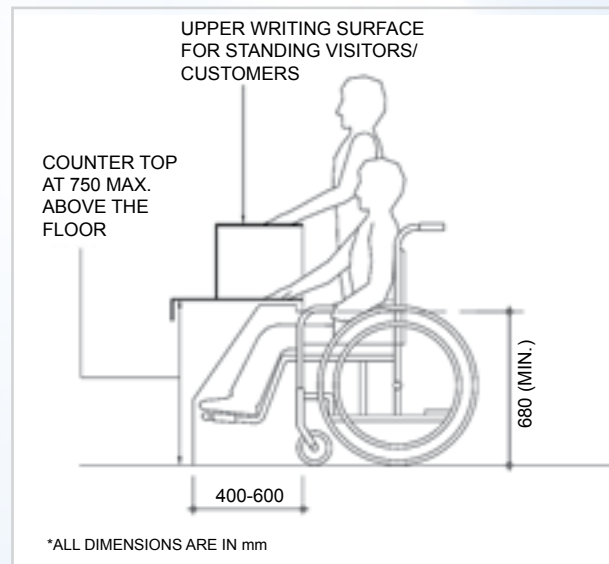

# Chapter -12 Illumination

This Chapter deals with the requirements for lighting provisions in various areas with respect to the accessible environment.

## Performance Objectives

Sufficient level of illumination shall be provided in order to help people to apprehend the physical environment of the space they have entered or to move around safely.

## General Illumination Level

The following designated areas of a building, where reasonably expected to be used by the public or occupants of the building during the period of normal use or occupation or when required, shall have minimum illumination level measured at the finished floor level along the centre line of the passageway as follows: -

Ground floor entrance lobby and lift	120 lux
Lift lobby of upper floors, corridors, accessible paths and stairs cases	85 lux

## Illumination Level for Signs

Signs provided under Division 13 shall have illumination level on the sign surface of not less than 120 lux.

## Means of Provision of Illumination

The illumination may be provided through automatic or manual switching devices.

## Design Considerations

- Artificial lighting should be designed to give uniform illumination and good colour rendering of all surfaces, without creating glare, or pools of bright light and strong shadows.
- Where appropriate, lighting should be so designed to illuminate the face of a person speaking in order to make communication easier.

## Common Areas

Common areas of a building should have an illumination level of not less than 120 lux measured at the finished floor level.

## Lighting for Steps

Lighting with lower illumination level should be provided at the entrances and exits to provide a contrast between the treads and the risers.

## Illumination Level

Uniformity of illumination level should be maintained throughout the designated confined areas such as staircases, corridors or the like.

Higher illumination level at the entrance doors to flats and the exit doors should be provided.

## General Lighting

Contrast will only be of assistance to people with visual impairment if there is an appropriate quantity and quality of illumination with which to view the contrasting elements. At low light levels, the perception of contrast diminishes. Lighting levels should generally be relatively uniform and about 25% higher for people with low vision. Strong directional lighting casts shadows that can mask contrasting surfaces.

Significant fluctuations in illumination level can reduce visibility due to the slower adaptive response of the eye in someone with low vision. Effective uses of luminous contrast include:

- Contrasting tactile warning strips to indicate the start and finish of a ramp;
- Contrasting doorframes, doors, skirting boards and architraves to assist with locating doors;
- Contrasting paving at doorways to assist with locating the entry; and
- Contrasting edges of steps, a roadway or poles in play areas to highlight potential hazards.

# Chapter -13 Lifts

Lift provides means of vertical transportation to any user of the building to move from one floor to another.

## Performance Objectives

Where a lift is provided, appropriate provision shall be made for all people to travel vertically within the buildings conveniently and independently to other storeys and to make use of all v facilities.

## Special Requirements for Accessible Lifts

- Every floor of a building shall be accessible by at least one passenger lift which shall fully comply with all the obligatory design requirements as stipulated in this section and have direct access to main lift lobby.
- A lift shall have minimum internal car dimensions of 2000 mm x 1100 mm wide, with a minimum clear entrance width of 900 mm, and shall have handrails extending to within 150 mm of the corners at the rear and sides of the car.
- The top of the gripping surface of the handrails shall be at a height of 850 mm – 950 mm, with a space of 30 mm - 50 mm between the handrails and wall.
- Where there are more than three lifts in a building, access shall be provided to every floor by at least one lift having minimum internal car dimensions of 2000 mm x 1100 mm with a minimum clear entrance width of 900 mm.

## Lift Doors

- Lift car doors and landing doors shall be of the horizontally sliding type, power-operated and automatically controlled.
- An audible signal shall be provided to signify the closing of the doors to alert persons.

- A detection device shall be provided to re-open the lift doors in the event of hitting any obstacle.
- The detection device shall be positioned at a height of between 500 mm to 600 mm above the floor of the lift car.

## Lift Control Buttons

- Essential lift control buttons including floor numbering buttons, emergency alarm push button and door opening push button in the lift car shall not be less than 900 mm and not more than 1200 mm above the floor of the car.
- Lift call buttons at the lift halls shall not be less than 900 mm and not more than 1200 mm above the floor of the finished floor level of the lift hall.
- Provision of secondary control panel for over-spilled floor numbering buttons is always acceptable.
- All lift control buttons shall have a minimum dimension of 20 mm
- Braille and tactile markings shall be placed either on or to the left of the control buttons.
- Such Braille and tactile markings shall be in Arabic numerals and/or symbols. Tactile markings shall have a minimum dimension of 15 mm high and be raised 1 mm minimum.
- The tactile marking of the push buttons for the main entrance floor shall be identified with a symbol in a star shape (see
- The emergency alarm push button shall be in a tactile bell shape.

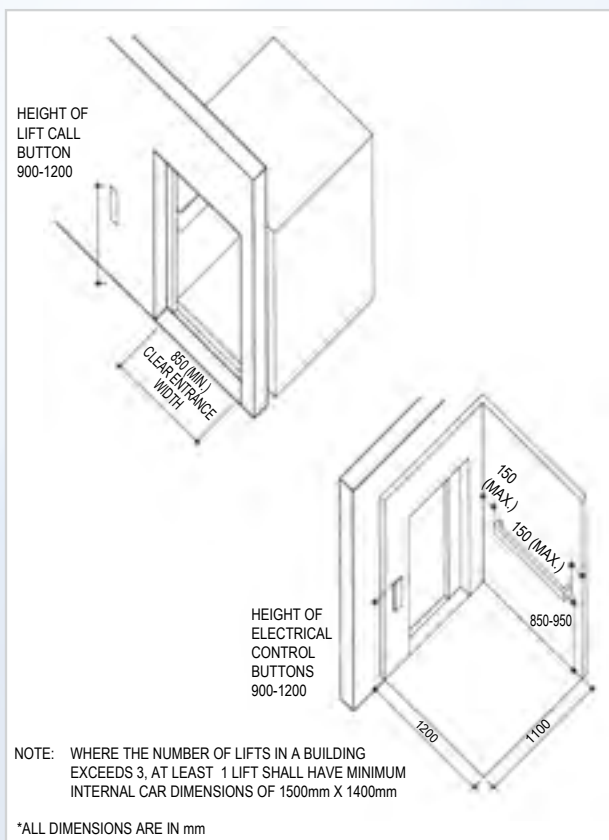
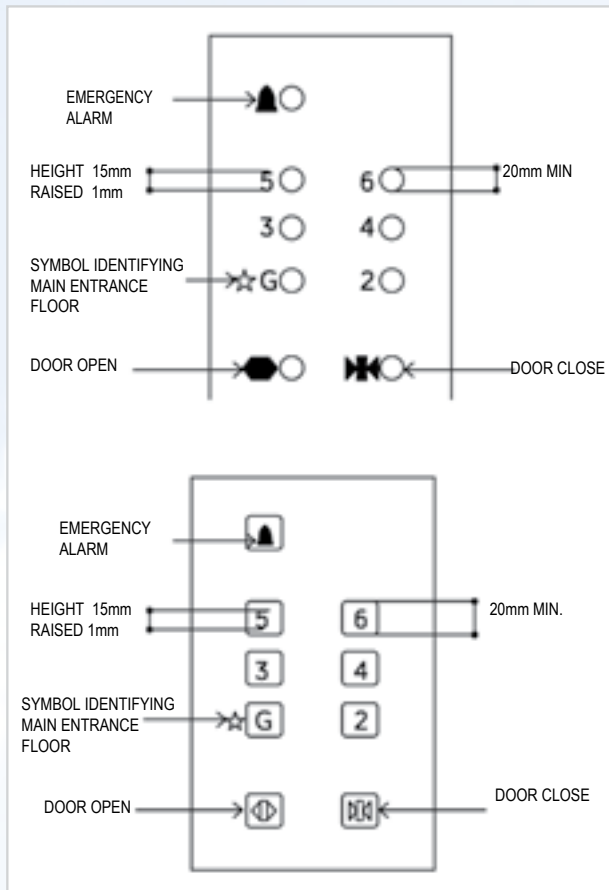

## Emergency Call Button in Lifts

- An emergency alarm push button together with a buzzer, an indication light for acknowledgement and an intercom shall be provided in each lift car and be connected to the building management office or the caretaker's office. The building
- Management office or the caretaker's office shall be equipped with a buzzer, indication light(s) (one for each lift) and an intercom connected to the lift car(s). The indication light for acknowledgement shall be in the form of a blinking light adjacent to the intercom speaker and a notice "When light blinks, it indicates your emergency call has already
- Been received. Please be patient and wait for the rescue." In English and Hindi shall be provided next to the blinking light.
- This system shall be powered by an emergency electricity supply system in the event of power failure.

## Design Considerations

- Lifts can help to provide access to storey above or below the main entrance level. If designed appropriately, lifts are the most convenient form of vertical access for persons with a disability. However, given the space constraints in some buildings, it may not always be possible to install the type and size of passenger lift that would be suitable for use by all, and other options may need to be considered to provide for users with ambulant impairments. Lift controls should be installed at the position which is within reach of all users including wheelchair users.
- A wheelchair user needs sufficient space and time to enter and leave a passenger lift, particularly when sharing it with other people. Lift sizes should therefore be chosen

to suit the anticipated frequency of use of the building and the needs of persons with a disability.

- Lift door systems should be designed to allow adequate time for passage of persons with a disability and the elderly.
- The use of visually and acoustically reflective wall surfaces can cause discomfort for persons with visual and hearing impairment.
- For lifts of the size that does not allow a wheelchair user to turn around within the lift car, mirror should be installed with the bottom edge to be set at 900 mm above the floor level in the lift car to facilitate a wheelchair user in reversing and to see which level the lift has reached.
- Where planning allows, lift cars may be provided with opposing doors to allow a wheelchair user to leave without having to reverse.

### Lift Control Buttons

The graphics for tactile markings for open-door and close-door push buttons, emergency alarm button, and main entrance level are shown in for reference.

Call button panels should be provided at both sides of door openings.

### Keypad design

- In cases where difficulties are encountered to fully comply with the obligatory requirements of installation of lift control buttons in high-rise buildings, keypad control device in conjunction with a conventional lift control panels in lifts for persons with a
- Disability should be provided. Proposed standardized positions of buttons for keypad control device.

- The keypad should: -
- Have control buttons of minimum dimension of 20 mm;
- Be installed between 900mm to 1200mm from finished floor level of the lift car;
- Have adequate luminous contrast between the tactile markings on the buttons and the background;
- Have voice announcement and visual indication of the floors registered
- Have instruction for the keypad control panel in the form of Braille or voice announcement beside the panel.

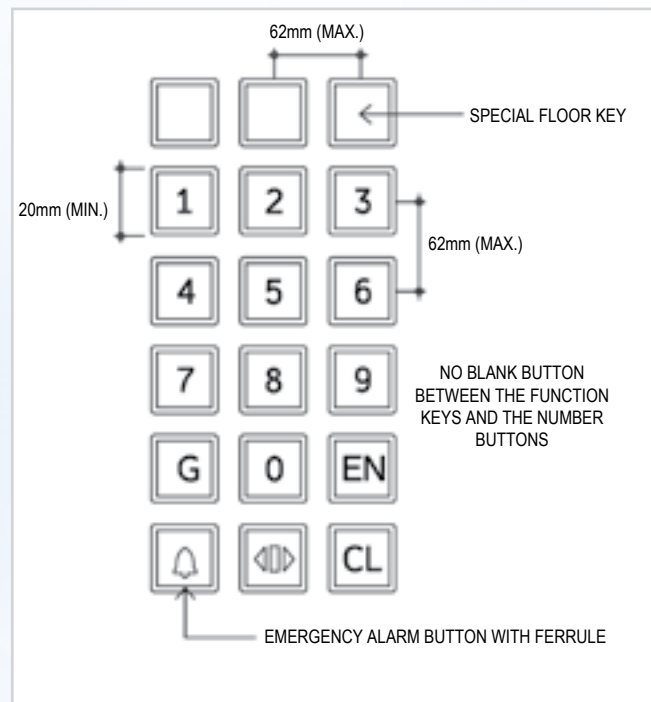



# Chapter -14 Escalators and Passenger Conveyors

Escalators and passenger conveyors provide means of vertical and horizontal transportation within a building respectively.

## Requirements for Escalators and Passenger Conveyors

Escalators or passenger conveyors are not considered part of a barrier-free route of travel. However, adequate warning or guarding shall be provided alongside and at each end of the escalators and passenger conveyors for the safety of persons with visual impairment.

### Tactile Warning Strips

- Tactile warning strips shall be provided at both bottom and top ends of an escalator.
- Tactile warning strips shall be provided at both ends of a passenger conveyor.

### Design Considerations

- Escalator can be a useful addition to stair and lift where significant height difference has to be negotiated, but it should be designed with slower speed for the safety use by persons with visual impairment and the elderly.
- The angle of inclination of escalator should not exceed 30°.
- Adequate distance for horizontal movement of steps is required at the top and bottom of escalator to ensure that passengers – especially those leaving the escalator – have adequate space and time to board and alight safely.
- Step edge should be clearly defined with colour in sufficient luminous contrast with the background, e.g. yellow colour against dark grey steps.
- Moving handrail should be in luminous contrast with the background.

- Passenger conveyor may be used when there is substantial traveling distance between pedestrian entrance and vehicular access point, e.g. in an airport terminal. It is mechanically similar to escalator which may be level or inclined.
- The same principles of luminous contrast as for escalator should apply to passenger conveyor.
- There must always be an alternative pedestrian route provided.

### Audio Indicator

For escalator and passenger conveyor, clear signal or indication for going up / down or moving forward should be provided on both ends, e.g. consistent clear sound or signals.

### Alternative Access

Where there is an accessible lift that provides alternative access route for persons with a disability, it should be near to, and clearly shown by a sign posted at the entry to the escalator.

# Chapter -15 Other Building Services

## Switches And Controls

This section is applicable to operable part of controls such as electrical switches, wall socket outlets and controls of other electrical and mechanical equipment.

Switches, socket outlets and controls for lighting and other equipment shall be located so that they are easily reachable for all users.

## Design Considerations

- Ease of operation, visibility, reachable height and free from obstruction are key factors that affect the use of building services by persons with a disability.
- All outlets, switches and controls should be positioned consistently in relation to doorways and corners within a building and in a logical sequence of passage through the building.
- Switches close to the floor or skirting are difficult to reach and dangerous because the users have to stoop or kneel to operate them. The higher the socket outlet, the easier it is to push in or pull out the plug. However, there may be exceptions to height requirements for some socket outlets, e.g. those set into the raised flooring in open plan offices.
- Operation of controls intended to be used by persons with a disability should not require the use of both hands simultaneously.
- To cater for persons with visual impairment, controls should be in colour and luminous contrast with the background, and with embossed information on them for tactile reading.

## Positioning

- Except as provided in for lifts, the controls for the operation of building services or safety devices including electrical switches,

light switches, thermostats, intercom switches and card reading machines which are intended to be accessible to wheelchair users should be located between 450 mm and 1200 mm above the finished floor level

- Electric sockets should be located not lower than 450 mm above the finished floor level.

## Luminous Contrast

Light switches and socket outlets should have a minimum luminous contrast of 30% with their background to indicate their locations.

## Controls

Controls should:

- Have a minimum luminous contrast of 30% with the background finishes;
- Be visible from a seated position
- Not be of small button type.

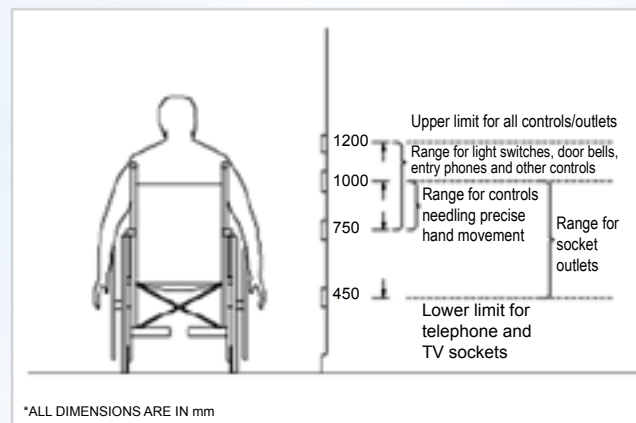

## FIRE ALARM SYSTEMS

Persons with hearing impairment depend on visual cues to alert them of emergencies. Persons with hearing impairment may need a visible as well as audible alarm which is only sufficient to deliver warning to a normal person.

## Performance Objectives

Where fire alarm systems are provided in areas of a building required to be accessible, the alarm shall emit both audible and visible signals.

## Visual Alarm

visual alarm signal shall be provided to form part of the fire alarm system in the form of a flashing red light, labeled “Fire Alarm in both English and Hindi. It shall be indicated on separate plate affixed nearby or engraved on the light cover. The alarm shall be installed at a prominent location which shall be readily noticeable when activated in the categories of buildings as specified in NBC 2005.

## Positioning of Call Points

The manual fire alarm call points or activation controls, e.g. break glass units, in places which are intended to be accessible to wheelchair users, shall be positioned at prominent and accessible locations.

## Audible Alarm

Audible alarm shall comply with the requirements of the Fire and Safety as per NBC 2005.

## Design Considerations

Audible and visual alarm may not be appropriate for use in hospitals and some specialized medical facilities, such as operating rooms, where it is not intended to alert or alarm patients who are incapable of independent evacuation. The sudden strobe flash might disrupt a surgical operation in progress which could be catastrophic. For such facilities, the requirements for visual and audible alarm may be modified to suit the norm of industry-accepted practices.

## Public Telephones

This section sets out the requirements for telephones intended to be used by the public.

Public telephones should be accessible by all users, including wheelchair users and persons with visual or hearing impairment.

## Design Considerations

- Telephones should be fixed at an appropriate height which is within easy reach and easy to use, to enable all users, including persons with a disability to make full use of them.
- Other helpful features which should be provided include support rails; adequate lighting; seats; big buttons; lamp signaling; amplifying handset; inductive coupler; speakerphone; and digit indicator.



## Telephone for Persons with Ambulant Disabilities and Wheelchair Users

- At least one in a group of two or more payphones should be designed for access by persons with a disability and in compliance with the following: -

- The approach to the accessible payphone should be free of obstacles;
- The accessible payphone should not be placed on a stepped base unless a ramp in compliance with Division 5 is provided;
- The cord length of the accessible payphone should not be less than 750 mm;
- To facilitate wheelchair users, all operable parts including the coin slot of the accessible payphone should not be positioned higher than 1200 mm above the finished floor level;
- If there is an enclosure for the accessible payphone, the enclosure should begin no more than 650 mm from the finished floor level to prevent it from being a hazard to persons with visual impairment;
- There should be a clear floor space of at least 750 mm by 1200 mm in front of the accessible payphone to allow either a forward or parallel approach by a wheelchair user;
- If a parallel approach is adopted, the enclosure sides, if there is an enclosure, should not extend more than 250 mm in front of the face of the accessible payphone;
- If a forward approach is adopted, the enclosure, if any, should have a clear width of at least 800 mm to provide wheelchair access; shelves or other obstructions should not extend more
- Than 400 mm from the face of the accessible payphone; and here should be a space of 750 mm wide by 650 mm high by 430 mm deep for the footplate of a wheelchair;
- If the accessible payphone is provided in an enclosed booth, the door of the booth should open outwards and have a clear width of not less than 800 mm between the open door and the
- Opposite jamb or the other leaf; and
- If the accessible payphones are provided in

a booth without door, the entrance to the booth should not be less than 800 mm wide.

- Grab rails should be installed on each side of the accessible payphone booth to enable those on crutches or with canes to maintain balance while using the accessible payphone. Otherwise, there should be a space of not less than 900 mm in width in the
- Phone booth for persons with a disability to enter with their crutches and canes.
- A fold-down seat should be provided in accessible booths for the convenience of persons with ambulant disabilities.

### **Telephone for Persons with Visual Impairment**

- At least one in a group of two or more payphones should be designed for access by persons with visual impairment. Such payphone should be provided with a mechanical keypad with the digit indicator and a detection system that activates a recorded sound message, giving explanations on the operational procedures to the users, as the handset is picked up.
- Phone cards for payphones should bear a “notch” on the left bottom to aid orientation for persons with visual impairment.

### **Telephone for Persons with Hearing Impairment**

At least one in a group of two or more payphones should be provided with amplifying handset or receiver with inductive coupler. If a payphone is equipped with the latter, it should be identified by the international symbol of access for persons with hearing impairment

## Telephone for Persons With Speech Impairment

At least one in a group of two or more payphones should be capable of handling written messages for access by persons with speech impairment.

## Drinking Water Area

A drinking fountain is a primary means for providing the public with water.

## Design Considerations

- The design and provision of drinking fountains should take into account the envisaged use of persons with a disability.
- The operable controls and direction of water flow should be designed and installed in a manner to facilitate the use by persons with a disability.
- Facilities for wheelchair users call for extra consideration in relation to access and maneuvering space.

## Provision

Where drinking fountains are provided, at least one of the drinking fountains on a given floor should have a design complying with this section.

## Spout

The fountain spout should: -

- Have an opening located between 750 mm to 900 mm from the floor or ground surface;
- Be located near to the front of the unit;
- Direct the water flow in a trajectory that is parallel or nearly parallel to the front of the unit
- Provide a flow of water at least 100 mm high to allow for the insertion of a cup or glass.

- Automatic controls or controls with handles of the lever type operable with a closed fist should be provided.

## Control

Controls should: -

- Be at or near to the front of the fountain;
- Be operable with one hand; and
- Require no tight grasping, pinching, or twisting of the wrist.

## Spatial Arrangement

The spatial arrangement should allow for the provision of: -

- A clear floor space of at least 750 mm x 1200 mm;
- A clear knee space of at least 750 mm wide, 200 mm deep and 680 mm high between the bottom of the apron and the floor or ground;
- A toe space not less than 750 mm wide, 230 mm deep and 230 mm high.
- All wall-mounted drinking fountains should be placed in an alcove to eliminate the hazard of collision to persons with visual impairment.
- A wall guard should be installed to protect a drinking fountain that extends into a corridor and has an open space underneath.

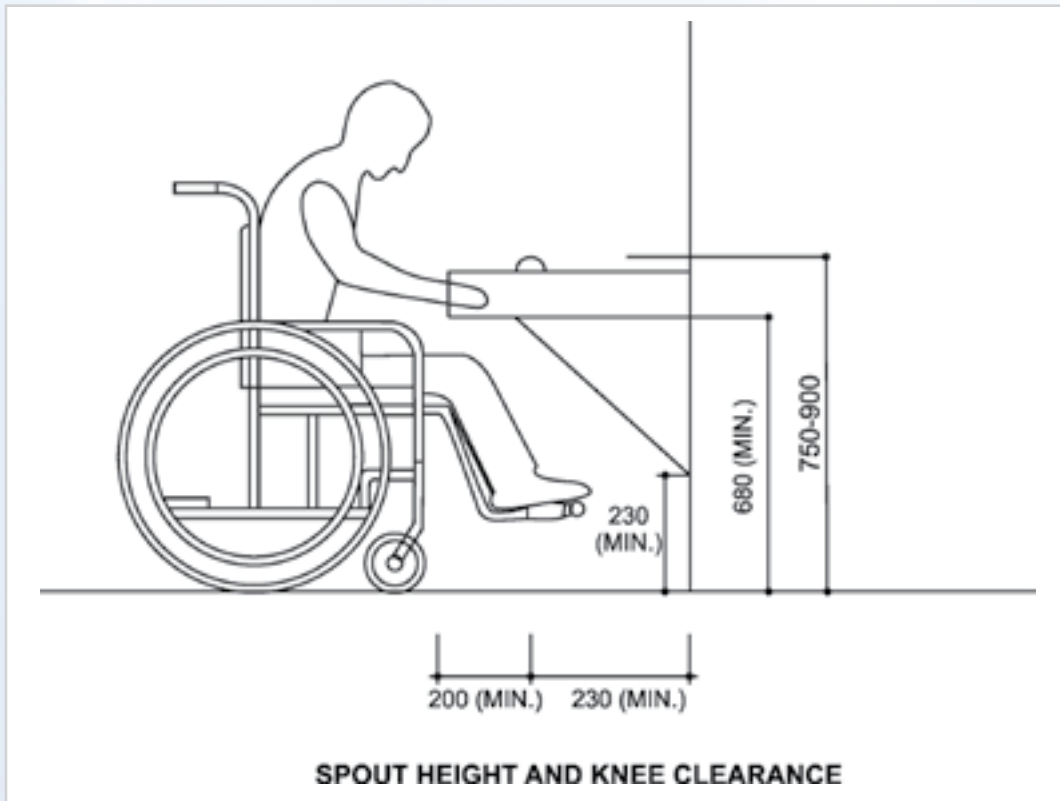
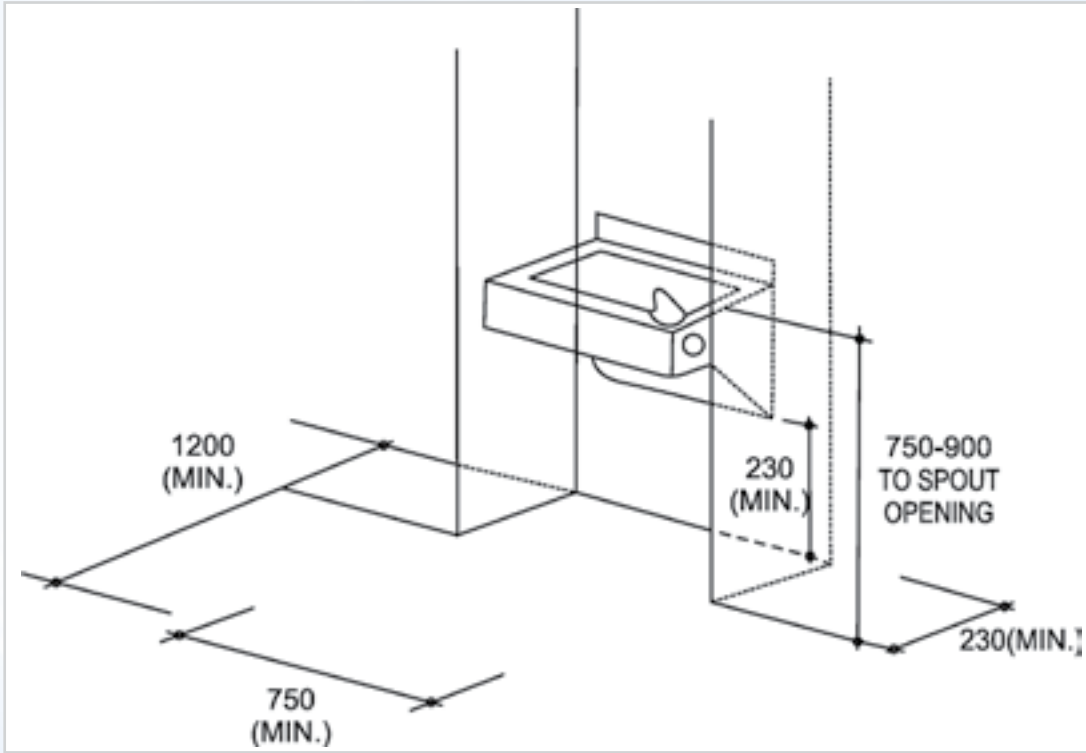

# Chapter -16 Anthropometrics

## Objective:

This chapter contains dimensional data which can be used for guidance when designing facilities and equipment for use by persons with a disability.

## Considerations:

The dimensions of the individual human being vary with time and from one person to another. In addition, the average dimensions vary from one country to another. When carrying out detailed design, consideration should be given to size variation between males and females as well as between different ages.

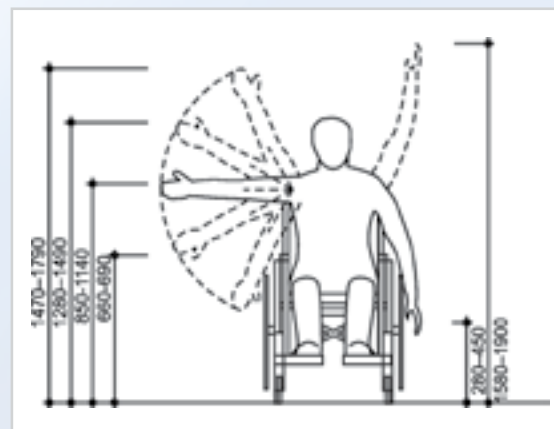
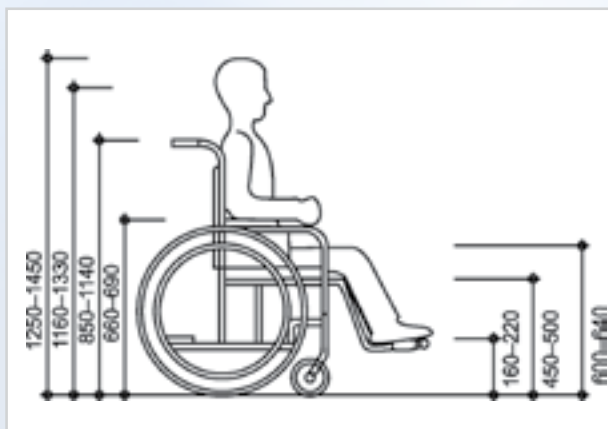
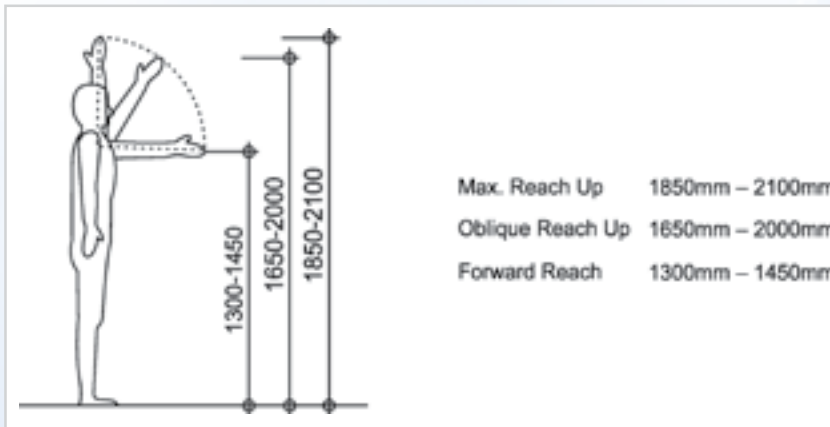
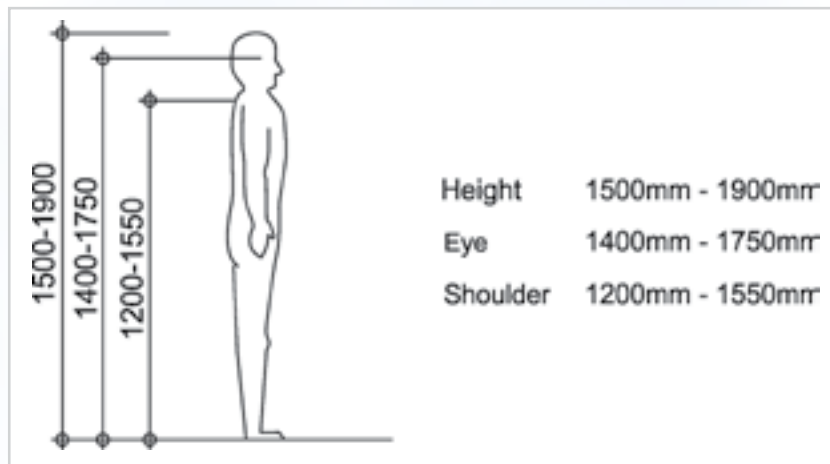

## Forward reach of a wheelchair user

The maximum forward reach, without obstruction, is 1200 mm from the floor and the minimum forward reach is 400 mm from the floor as shown in Figures. The maximum forward reach over an obstruction 500 mm deep is 1100 mm from the floor.

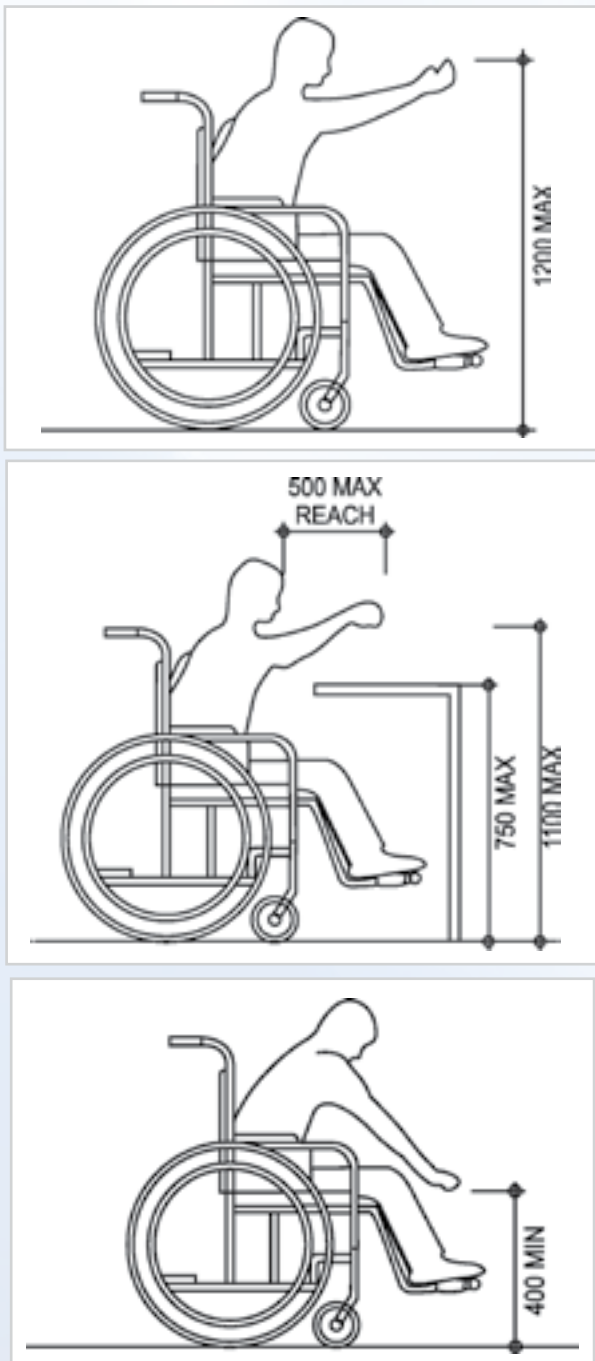

## Side reach

The maximum side reach, without obstruction, is 1300 mm from the floor and the minimum side reach is 250 mm from the floor as shown in Figures. The maximum side reach over an obstruction 860 mm high by 500 mm deep is 1200 mm from the floor.

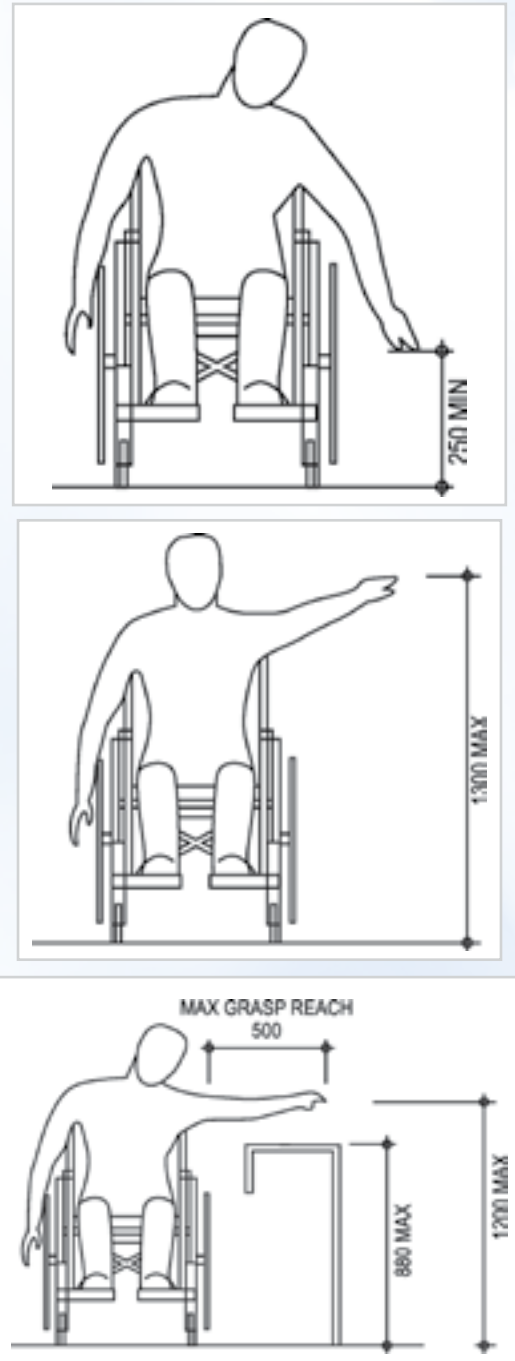



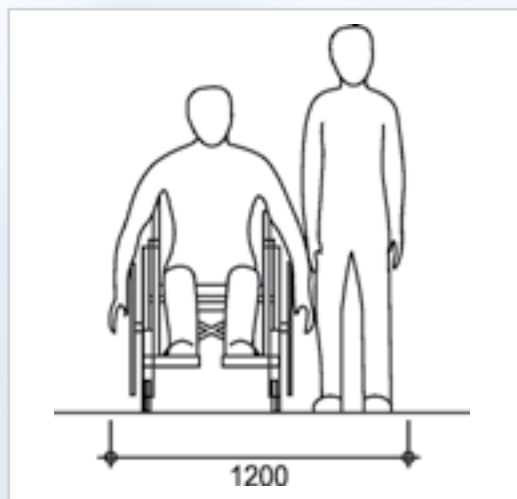
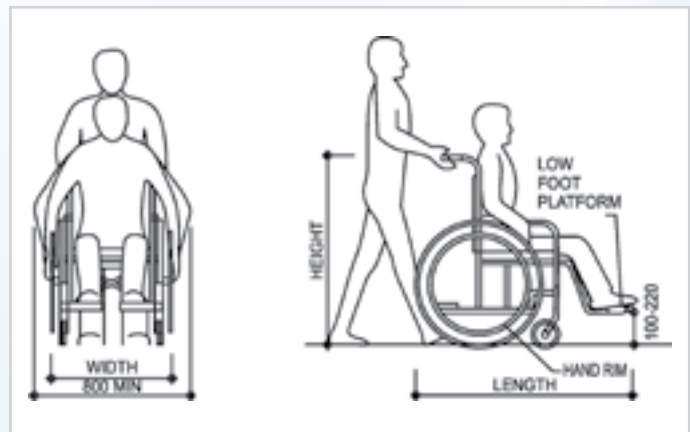
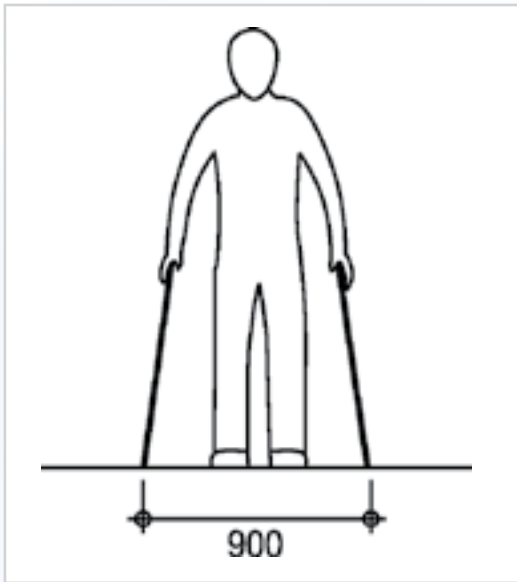
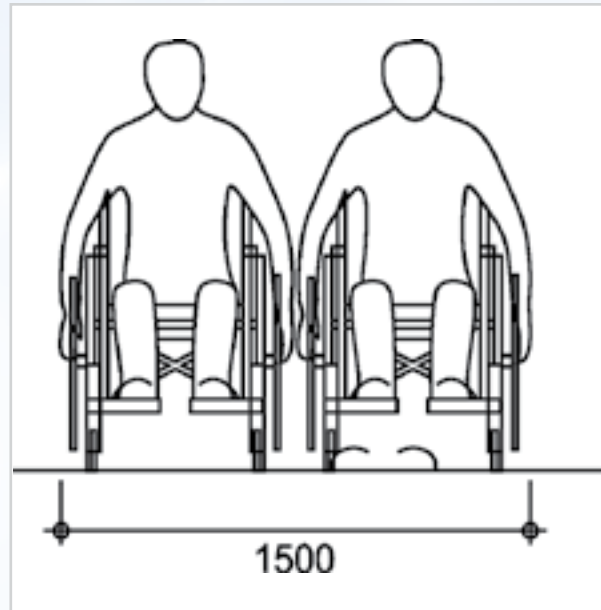
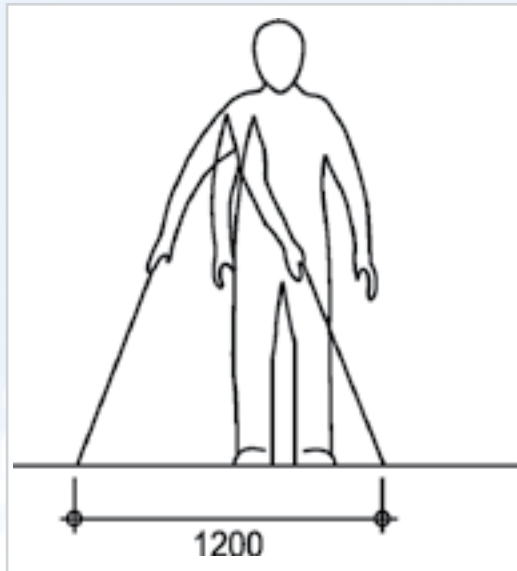

Type of Wheelchair	Width	Length	Height	Weight
Manual Wheelchair	510-725mm	645-1100mm	850-1140mm	10.27 kg
Electric Wheelchair	520-700mm	1060-1200mm	1010-1400mm	36.100kg

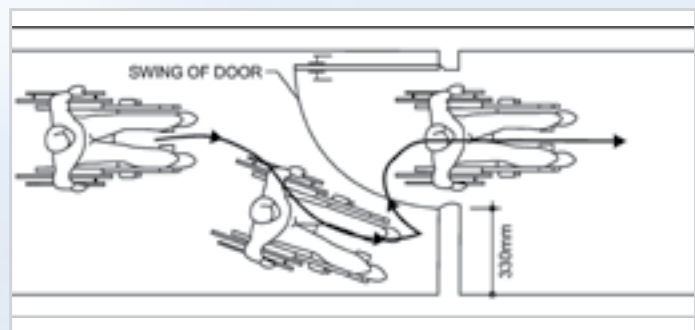

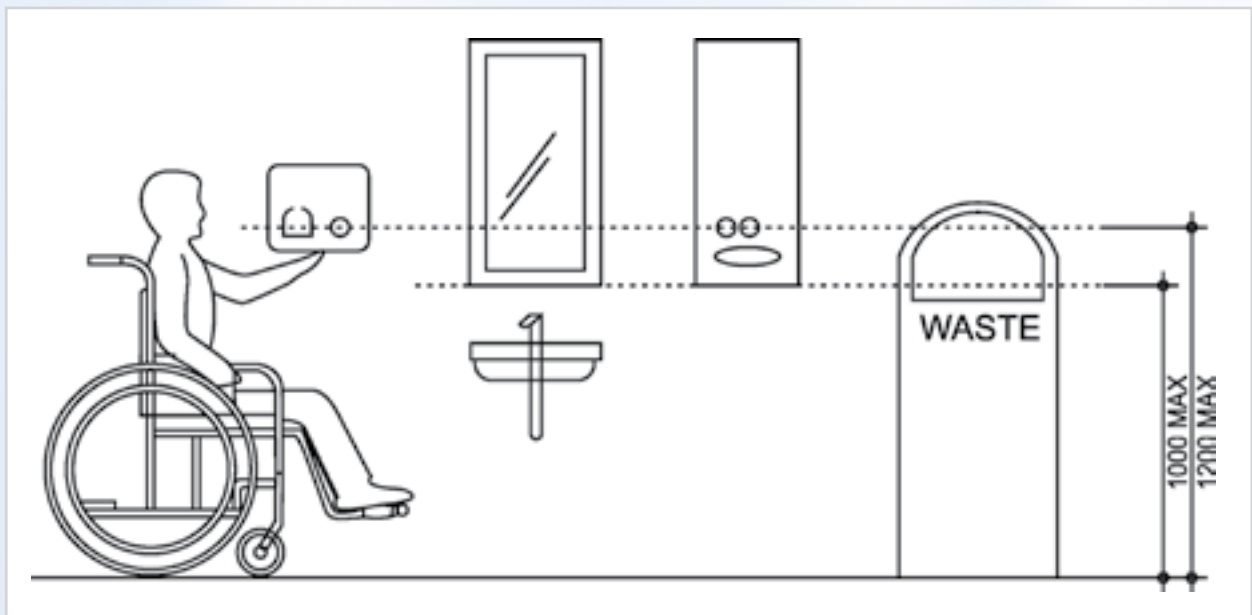
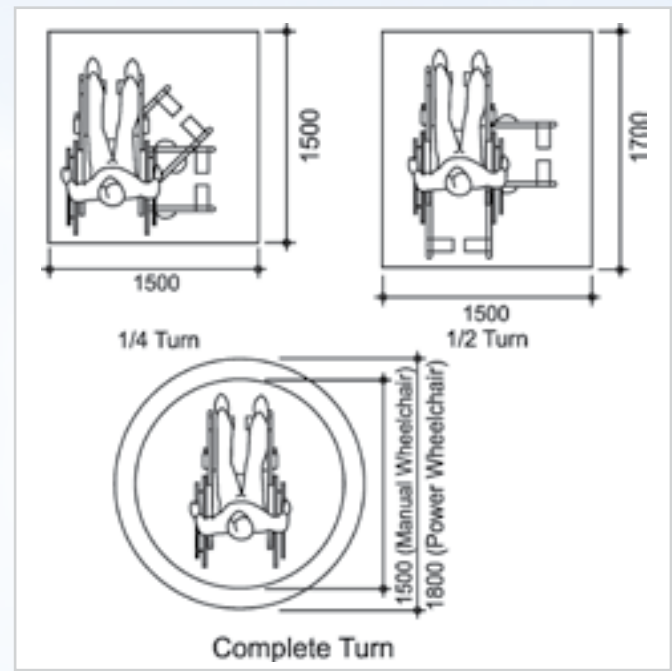
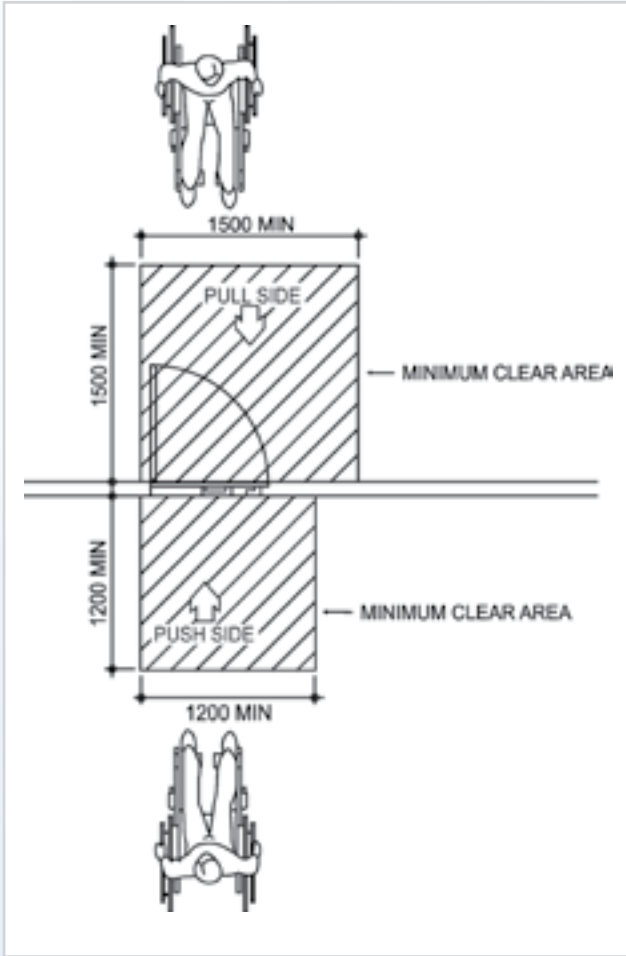

# Chapter -17 Car Parking

This Chapter aims to provide standards for accessible car parking spaces designated for the use of persons with a disability.

## Ratio of Accessible Parking Spaces

Adequate numbers of accessible car parking spaces shall be provided with proper access, proper designation and directional signage in the car parks.

Total No. Car Parking Space in Lot	Required No. of Accessible Car parking Spaces
1-50	1
51-150	2
151-250	3
251-350	4
351-450	5
Above 450	6

## Requirements for Accessible Parking Spaces

- The parking spaces reserved for persons with a disability shall be located in proximity and with an accessible route to the lobby with an accessible lift or entrance.
- The minimum width for a parking space for persons with a disability shall be 3600 mm.
- Where a common loading/unloading area is provided between two parking spaces for persons with a disability, such parking spaces shall be not less than 3600 mm in width.
- The common loading/unloading area shall have at least 1200 mm wide and be marked with yellow hatched markings.

### Marking Requirements for Accessible Parking Spaces

The parking space shall be clearly marked with the international symbol of accessibility and the parking space number on the floor.

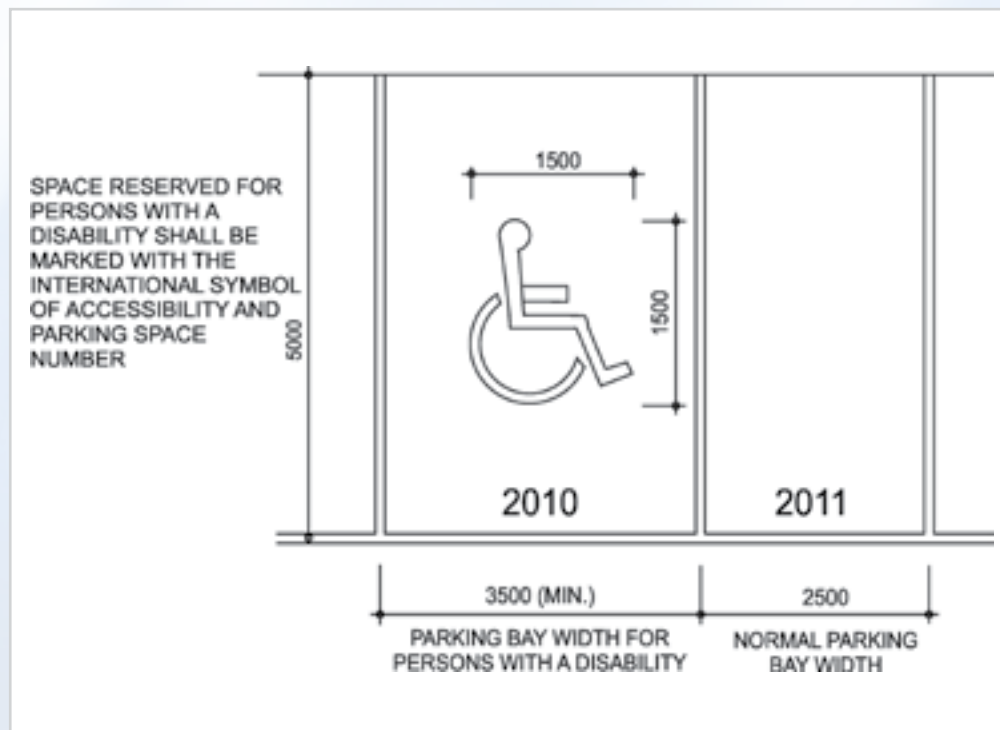

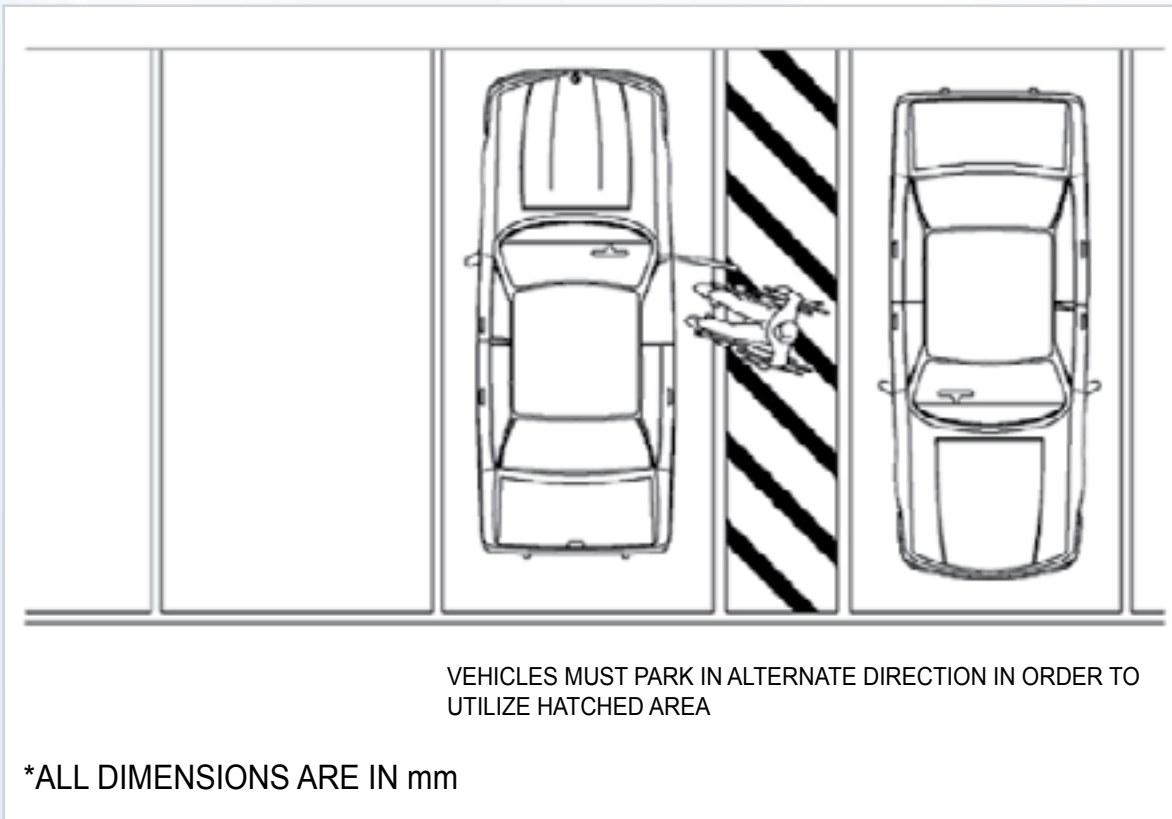
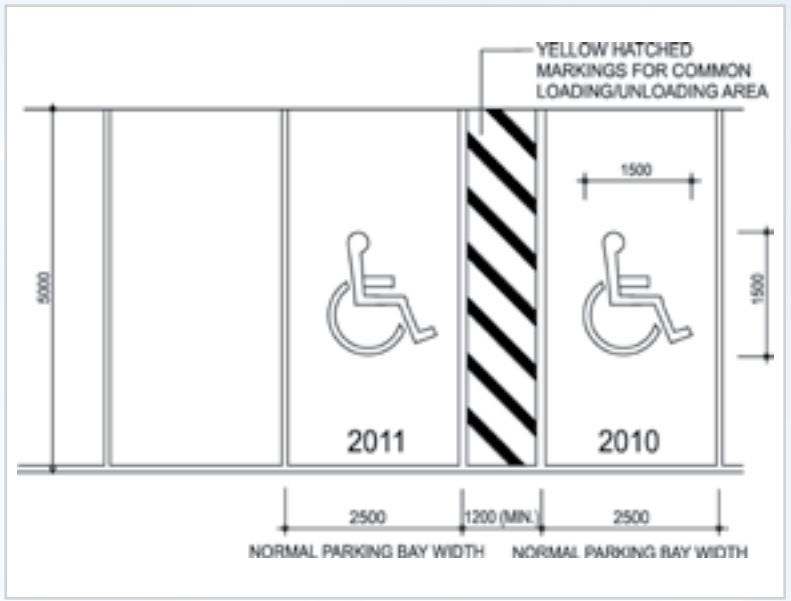
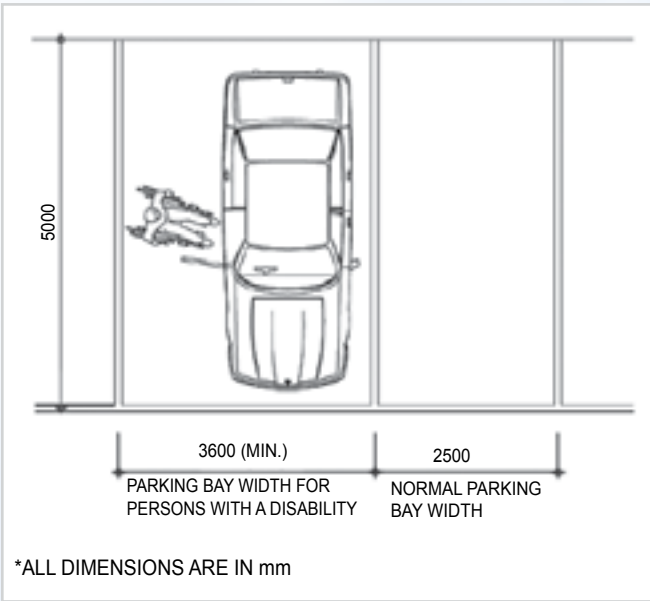

## Design Considerations

- Persons with ambulant impairment who arrive as passengers should be able to alight conveniently from a vehicle close to the principal entrance, or alternative accessible entrance, of the building.
- The parking bay surface should allow the safe transfer of a passenger or driver to a wheelchair and transfer from the parking bay to the access route to the building without undue effort, barriers to wheelchairs or hazards from tripping.
- Where a ticket dispensing machine is installed, it should be located properly to allow wheelchair users, or persons of short stature, to approach conveniently to the machine and perform the payment and ticket dispensing functions.

## Recommended Design Requirements

- At the entrance of public parking facilities, signage should be displayed in prominent positions to indicate the designated numbers of the parking spaces reserved for persons with a disability
- Indication / directional signage along driveway showing the way leading to the parking spaces reserved for persons with a disability should be provided.

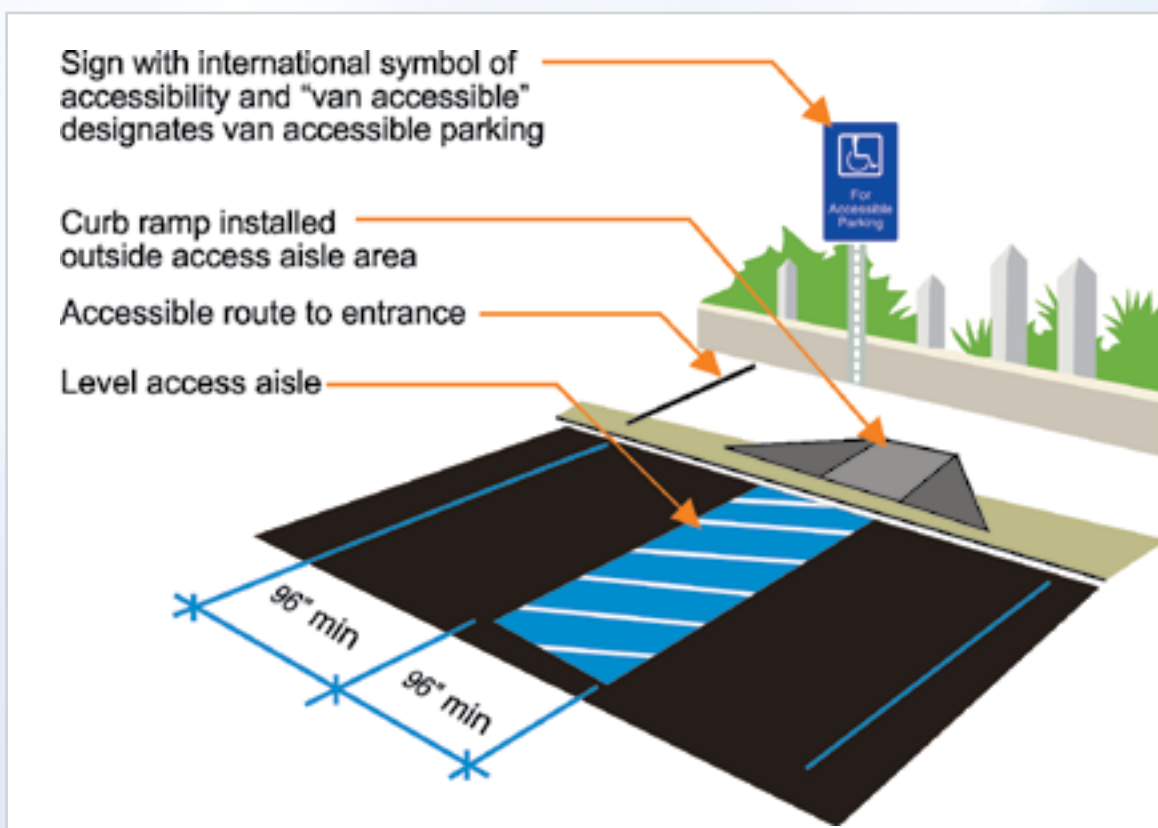

# Chapter -18 Implementation of Barrier free Provisions

All the Barrier free provisions have been successfully implemented in all the government office buildings maintained by CPWD, after the access audit being carried out. In these provisions in existing buildings following measures can be implemented easily without damaging the existing structure:-

- Access Ramps
- Way Finding Signage and General Signage
- Unisex Barrier Free Toilet
- Handrails on existing Staircase
- Accessible Car Park
- Tactile Guiding Path









## Chapter -19 Case Study on making Indira Paryavaran Bhawan a Barrier Free Building

Indira Paryavaran Bhawan has been designed as a completely accessible building. Various measures have been taken to make sure that the building is user-friendly and accessible to all the people irrespective of their age and physical capabilities.

Tactile guiding path has been provided to guide the disable people from the Entrance of the campus to the main building.

Ramps have been provided from the road level to the plinth level to access the building. Accessible lifts, corridors, signage and Unisex Barrier free toilets have been provided inside the building.



# Chapter -20 International Practices in Barrier Free Standards

S. No	Topic		Barrier Free Guidelines by MoUD	Disability Discrimination Act, European Union	Barrier Free Guidelines Toronto, Canada	Barrier Free Guidelines United States of America
1	Reach	Forward Reach	1300 mm High	1000 mm (comfortable) 1100 mm (extended)	Not Specified	1220 mm High
			380 mm Low	650 mm (comfortable) 650 mm (extended)	Not Specified	380 mm Low
		Side Reach	1300 mm Max	1060mm (comfortable) 1160mm (extended)	1370 mm	1370 mm High
			230 mm Low	665 mm (comfortable) 630mm (extended)	460 mm	230 mm Low
		Forward Reach with obstruction	1100 mm High with 600 max arm stretch	Not Specified	Not Specified	1220 mm
			1100 mm High with 600 max arm stretch	Not Specified	1220 mm	1170 mm
2	Space Allowance	Clear floor space for 1 wheelchair	900w x 1200d	1000mm clear min. width	760 mm X 1220 mm	760w x 1220d
		Clear space for passing 2 wheelchairs	Not Specified	2000 mm	Not Specified	1525 mm
		For Rotating 1 wheel chair	1500 x 2000	1500 x 1500	Not Specified	1525 x 1525
		For right angle turning the corridor	Not Specified	1200 x 1200	Not Specified	1525 x 1525
		180 degree turn	Not Specified	1600 x 2000	Not Specified	Not Specified

S. No	Topic		Barrier Free Guidelines by MoUD	Disability Discrimination Act, European Union	Barrier Free Guidelines Toronto, Canada	Barrier Free Guidelines United States of America
3	Controls	Doors handles, lift buttons, Handrails switches, etc	Shall not be higher than 1400 mm	Height of all the controls shall not be less than 750mm and not be more than 1200mm above ground level.	Shall not be higher than 1200 mm	Not Specified
			Shall be placed between 900-1200		Shall be provided at 915 mm	Not Specified
			power points shall be between 400-500 from finished floor level.		Not Specified	Not Specified
4	Levels & Ramps	Maximum Gradient	1:12	1:12	1:12	1:12
		Min. Width	1800mm	2000 mm	1670 mm	915
		Maximum Length of Ramp in one go	9 Meter	2 Meter	9 Meter	9 Meter
		Height of Handrail	between 800-900mm	between 550 -1100 mm	Not Specified	between 865 -965 mm
		Minimum Gap between Handrail and wall	50 mm	50-60 mm	40 mm	38 mm
		Diameter of Handrail	40 mm	40 - 50 mm	30 - 50 mm	32 - 38 mm

S. No	Topic		Barrier Free Guidelines by MoUD	Disability Discrimination Act, European Union	Barrier Free Guidelines Toronto, Canada	Barrier Free Guidelines United States of America
5	Entrance & Exit Doors	Minimum Clear Openings	900 mm	900 mm	915 mm	815 mm
		threshold level difference	not more than 12 mm	Not Specified	Not Specified	not more than 19 mm
		Height of Door Handle from Floor lvl	900 mm - 1000 mm	900 mm	915 mm -1065 mm	Not higher than 1220 mm.
		Door Handle Length	100 mm	120mm	Not Specified	Not Specified
		Diameter of Door Handle	Not Specified	30-35 mm	Not Specified	Not Specified
		Clearance of door handle from door	Not Specified	45 mm	Not Specified	Not Specified
		Door Closer	Not Specified	Automatic	Not Specified	Sweep period of closer with a closing time of 3 second
6	Parking	car	for 2 cars	Not Specified	Not Specified	Fo 2 Accessible Vans
		Parking Bay	2500 mm wide	Not Specified	3600 mm	2440 mm wide
		Unloading Platform	1200 mm	Not Specified	1500	1525 mm
7	Lifts	No. of Lifts	One Lift is provided	Not Specified	Not Specified	Not Specified
		Clear Internal Dimentions	1100 mm X 2000 mm	1400 mm X 2000 mm	1725 mm X 2286 mm	Not Specified
		Entrance Door Widths	900 mm	900 mm	915 mm	Not Specified
		Lift control heights	1000 mm High	1100 mm	Not Specified	1370 mm High

S. No	Topic		Barrier Free Guidelines by MoUD	Disability Discrimination Act, European Union	Barrier Free Guidelines Toronto, Canada	Barrier Free Guidelines United States of America
8	Toilet	Size of Toilet	1500 X 1750 mm	2200 X 1500 mm	1500 X 1675 mm	2134 X 1575 mm
		Flooring Material	Non Slip Surface without level difference	Matt or Mid-sheen finishes are recomnded	Not Specified	Not Specified
		Door Shutter	Light Weight door shutter	Not Specified	Not Specified	Push and pull type door not more than 22.2 N weight. Grab bars are not mounted above 1219 mm.
		Door Shutter Opening	900 mm	925 mm	810 mm	813 mm
		Grab Bars	40 mm dia vertical grab bar up to 2100 high	38 mm dia vertical grab bar up to 1280 high	Vertical Grab bar L type Height is not specified	Horizontal Grab bars 1321 mm widw along WC
		WC Height	500 mm	480 mm	430 mm -460 mm	356-483 mm
		Wash Basin Height	750-800 mm	720-740 mm	Not Specified	686 mm
		Urinal Height	Not Specified	Rim height shall be 380mm from floor lvl	Not Specified	Not Specified
		Faucets	Not Specified	Not Specified	Automatic Type	Self closing faucet valves
Signage	Braille Signage at 1400 mm along with illuminated symbol for disabled at 1500 mm	Not Specified	Not Specified	Not Specified		

S. No	Topic		Barrier Free Guidelines by MoUD	Disability Discrimination Act, European Union	Barrier Free Guidelines Toronto, Canada	Barrier Free Guidelines United States of America
9	Signages	Height of Letters	Depends on Viewing distance (2m. To 50m) ranges from 6 mm - 150 mm	Depends on Viewing distance (1 % of distance at which the message read) Minimum shall be 22 mm	Depends on Viewing distance Minimum shall be 25 mm along with Braille lettering below	Depends on Viewing distance Minimum shall be 75 mm
		Height for Notices/ signs for wheelchair users	750 mm	Not Specified	Not Specified	Not Specified
		Height for door, safety or other notices for ambulant users	1200 mm	1400 mm with bottom edge not less than 900 mm	Between 1370 mm - 1525 mm	Not Specified
		Minimum Clearance for suspended or projected signs	2000 mm	2300 mm	Not Specified	2030 mm

# Chapter -21 Relevant Extract From National Building Code 2005

## **SPECIAL REQUIREMENTS FOR PLANNING OF PUBLIC BUILDINGS MEANT FOR USE OF PHYSICALLY CHALLENGED**

### **D-1 General**

### **D-2 Site Development**

#### **D-2.1**

Almost any building can be made accessible to physically challenged persons by so planning the site that the terraces, retaining walls and winding walks are used effectively.

##### **D-2.1.1**

Site development is the most effective means to resolve the problems created by topography, definitive architectural designs or concepts, water table, existing streets, and typical problems, singularly or collectively, so that ingress, egress and access to buildings by physically challenged may be facilitated while preserving the desired design and effect of the architecture.

### **D-2.2 Walks**

D-2.2.1 Public walks should be at least 1200 mm wide and should have a gradient not greater than 1 in 20.

#### **D-2.2.1.1**

It is essential that the gradient of walks and driveways be less than that prescribed for ramps, since walks would be devoid of handrails and kerbs and would be considerably longer and more vulnerable to the elements. Walks of near maximum grade and considerable length should have level areas at intervals for purposes of rest and safety. Walks or driveways should have a non-slip surface.

#### **D-2.2.2**

Such walks shall be of a continuing common surface not interrupted by steps or abrupt changes in level.

#### **D-2.2.3**

Wherever walks cross other walks, driveways, or parking lots they should blend to a common level.

##### **D-2.2.3.1**

This requirement, does not require the elimination of kerbs, which, particularly if they occur at regular intersections, are a distinct safety feature for all of the challenged, particularly the blind. The preferred method of meeting the requirement is to have the walk incline to the level of the street. However, at principal intersections, it is vitally important that the kerbs run parallel to the street, up to the point where the walk is inclined, at which point the kerb would turn in and gradually meet the level of the walk at its highest point. A less preferred method would be to gradually bring the surface of the driveway or street to the level of the walk. The disadvantage of this method is that a blind person would not know when he has left the protection of a walk and has entered the hazards of a street or driveway.

#### **D-2.2.4**

A walk shall have a level platform at the top which is at least 1500 mm long, if a door swings out onto the platform or towards the walk. This platform shall extend at least 300 mm beyond each side of the doorway.

#### **D-2.2.5**

A walk shall have a level platform at least 900 mm deep, if the door does not swing onto the platform or towards the walk. This platform shall extend at least 300 mm beyond each side of the doorway.

## D-2.3 Parking Space

### D-2.3.1

Spaces that are accessible and approximate to the facility should be set aside and identified for use by individuals with physical disabilities.

### D-2.3.2

A parking space open on one side, allowing room for individuals in wheelchairs or individuals on braces and crutches to get in and out of an automobile onto a level surface, is adequate. It should have a minimum width of 2700 mm preferably 2 800 mm for ambulant disabled and minimum 3 000 mm preferably 3300 mm for wheel chair users.

### D-2.3.3

Parking spaces for individuals with physical disabilities when placed between two conventional diagonal or head-on parking spaces should be 3.6 m to 3.8 m wide and the length of the aisle should 7.3 m, 6.1 m and 6.5 m for head-on, 90° and 60° parking respectively.

### D-2.3.4

Care in planning should be exercised, so that individuals in wheelchairs and individuals using braces and crutches are not compelled to wheel or walk behind parked cars.

### D-2.3.5

Consideration should be given to the distribution of spaces for use by the disabled in accordance with the frequency and persistency of parking needs.

### D-2.3.6

Walks shall be in conformity with D-2.2.

## D-3 BUILDINGS

### D-3.1 Ramps with Gradients

Where ramps with gradients are necessary or desired, they shall conform to the following requirements.

#### D-3.1.1

A ramp when provided should not have a slope greater than 1 in 20 or maximum of 1 in 12 for short distance up to 9000 mm.

#### D-3.1.2

A ramp shall have handrails on at least one side, and preferably two sides, that are 900 mm high, measured from the surface of the ramp, that are smooth, and that extend 300 mm beyond the top and bottom of the ramp. Where major traffic is predominantly children, the handrails should be placed 760 mm high.

#### D-3.1.3

A ramp shall have a surface that is non-slip surface and if length is 3500 mm, the minimum width shall be 1500 mm.

#### D-3.1.3.1

The provision of non-slip surfaces on ramps greatly assists the challenged persons with semi ambulatory and ambulatory disabilities. Non-slip surfaces are provided by many finishes and materials.

The surfaces of the concrete ramps can be made nonskid by brooming the surface or by finishing with an indenting roller.

#### D-3.1.4

A ramp shall have a level platform at the top which is at least 1 800 mm long, if a door swings out onto the platform or toward the ramp. This



platform shall extend at least 300 mm beyond each side of the doorway (see Fig. 11). D-3.1.5 Each ramp shall have at least 1800 mm of straight clearance at the bottom.

### D-3.1.6

Ramps shall have level platforms at 10 m to 12 m intervals for purposes of rest and safety, and shall have platforms minimum 1.5 m length wherever they turn.

### D-3.1.7

For visually impaired people, ramps may be colour contrasted with landing.

### D-3.1.8

To minimize rise to wheelchair users, ramps should be equipped with kerbs approximately 50 mm high at exposed sides.

## D-3.2 Entrances

### D-3.2.1

At least one primary entrance to each building shall be usable by individuals in wheelchairs and shall be indicated by a sign.

### D-3.2.2

At least one entrance usable by individuals in wheelchairs shall be on a level that would make the elevators accessible.

## D-3.3 Doors and Doorways

### D-3.3.1 Doorwidth

To enable wheelchair users to pass through doors, the minimum clear width should be 900 mm and shall be operable by a single effort. In certain cases the width should be 900 mm to 1000 mm, for example, if the wheelchair has to be turned in the doorway, where there is a door-closer or at

entrance doors to public buildings and in other situations where there is considerable traffic.

### D-3.3.1.1 Two-leaf doors

They are not usable by those with disabilities defined in D-1.2.1, D-1.2.2 and D-1.2.5 unless they operate by a simple effort, or unless one of the two leaves meets the requirements of D-3.3.1.

### D-3.3.1.2 Side-hung doors

To facilitate wheelchair maneuver, doors should be hung with the hinges in room corners. Doors opening out into corridors or circulation spaces should be avoided as far as possible.

### D-3.3.1.3

It is recommended that all doors have kick plates extending from the bottom of the door to at least 400 mm from the floor, or be made of a material and finish that would safely withstand the abuse they might receive from canes, crutches, wheelchair foot-platforms, or wheelchair wheels.

## D-3.3.2 Wheelchair Maneuvering Space

To enable wheelchair users to approach doors maneuvering space is needed. A corridor should have a width of at least 1200 mm to allow a 90° turn to be made through a door. In narrow spaces sliding doors may be preferable.

### D-3.3.3 Thresholds

Raised thresholds should be avoided, but where this is not possible, their height should not exceed 25 mm. Rubber thresholds are advantageous for wheelchair users.

D-3.3.3.1 Care should be taken in the selection, placement and setting of door closers so that they do not prevent the use of doors by

the physically disabled. Time-delay door closers are recommended.

### **D-3.3.3.2 Self-closing doors**

Wheelchair users and other with impaired mobility have difficulty in using self-closing doors. The force required to open them should be reduced as far as possible. Public buildings should preferably have sliding automatic doors.

### **D-3.3.4 Door identification**

To help people with impaired vision to see doors, the door and frame should be in a color which contrasts with the adjoining wall. Glass or glazed doors should be marked with a colored band or frame, a little below eye-level.

### **D-3.3.5 Handles**

Door handles and locks should be easy to manipulate. To facilitate the closing of a door by wheelchair users (for example, a water-closet compartment), the door should have a horizontal handle approximately 800 mm from the floor. Self-closing doors should be equipped with an easy gripped vertical pull-handle with a length of at least 300-mm, and with the lower end approximately 800 mm above floor. For many people and specially those with impaired vision, it is helpful to make clear whether doors are to be pulled or pushed.

### **D-3.4 Windows**

Windows should be designed to avoid the glare which is a particular problem for people with impaired vision. Large glass areas close to circulation spaces should be marked a little below eye-level with a coloured band or frame. To enable wheelchair users to see through a window comfortably, the sill should be not higher than 800 mm from the floor. Windows should be easy to open and close. Their controls should be placed in the zone 900 to 1 200 mm from the floor.

## **D-3.5 Stairs**

Stairs should not be the only means of moving between floors. They should be supplemented by lifts or ramps.

### **D-3.5.1**

Straight flights of steps are preferred by ambulant disabled people. Treads should be approximately 300 mm deep and risers not higher than 150 mm. Steps should be of a consistent height and depth throughout the stair. Projecting nosing and open stairs should be avoided to minimize the risk of stumbling.

### **D-3.5.2**

Handrails should be provided to both sides of any stairway. They should be continuous and extend not less than 300 mm beyond the top and bottom step (otherwise it is difficult for the disabled to use the rail at the first and last step).

### **D-3.5.3**

For people with impaired vision, there should be a color contrast between landings, and top and bottom steps of a flight of steps, or the front edge of each step should have a contrasting color.

## **D-3.6 Floors**

### **D-3.6.1 Floors shall have a non-slip surface.**

### **D-3.6.2**

Floors on a given storey shall be of a common level throughout or be connected by a ramp in accordance with D-3.1.1 to D-3.1.8.

**D-3.6.2.1**

A gentle slope up to 10 mm may be given between the level of the floor of the corridor and the level of the floor of the toilet rooms.

**D-3.6.2.2**

There should not be a difference between the level of the floor of a corridor and the level of a meeting room, dining room, or any other room, unless proper ramps are provided.

**D-3.7 Sanitary Facilities**

It is essential that sanitary facilities, in accordance with the nature and use of a specific building or facility, be made accessible to, and usable by, the physically challenged.

**D-3.7.1**

Sanitary facilities shall have space to allow traffic of individuals in wheelchairs

**D-3.7.2**

Sanitary facilities shall have at least one water closet cubical for the ambulant disabled that:

- Is 900 mm wide;
- Is at least 1500 mm, preferably 1600 mm deep;
- Has a door (where doors are used), that is, 800 mm wide and swings out;
- Has handrails on each side, 780 mm high and parallel to the floor, 40 mm clearance between rail and wall, and fastened securely at ends and centre; and
- Has a water-closet with the seat 500 mm from the floor.

**D-3.7.3**

Sanitary facilities shall have wash basins with narrow aprons, which when mounted at standard height are usable by individuals in wheelchairs: or they shall have wash basins mounted higher, when particular designs demand, so that they are usable by individuals in wheelchairs.

**D-3.7.3.1**

The drain pipes and hot-water pipes under a sanitary appliance shall be covered or insulated so that a wheelchair individual do not find it inconvenient.

**D-3.7.4**

mirrors and shelves shall be provided above the wash basins at a height as low as possible and not higher than 1 m above the floor, measured from the top of the shelf and the bottom of the mirror.

**D-3.7.5**

Sanitary facilities for men shall have wall mounted urinals with the opening of the basin 460 mm from the floor, or shall have floor-mounted urinals that are on level with the main floor of the toilet room.

**D-3.7.6**

Toilet rooms shall have an appropriate number of towel racks, towel dispensers, and other dispensers and disposal units mounted not higher than 910 mm from the floor.

**D-3.8 Drinking Fountains**

An appropriate number of drinking fountains or other water-dispensing means shall be accessible to and usable by the physically disabled.

### **D-3.8.1**

Drinking water fountains or water coolers shall have up front spouts and control.

### **D-3.8.2**

Drinking water fountains or water coolers shall be hand-operated, or hand and foot-operated.

#### **D-3.8.2.1**

Conventional floor mounted water coolers may be convenient to individuals in wheelchairs if a small fountain is mounted on the side of the cooler 800 mm above the floor.

#### **D-3.8.2.2**

Fully recessed drinking water fountains are not recommended.

#### **D-3.8.2.3**

Drinking water fountains should not be set into an alcove unless the alcove is wider than a wheelchair.

## **D-3.9 Public Telephones**

An appropriate number of public telephones should be made accessible to and usable by the physically disabled.

### **D-3.9.1**

Such telephones should be kept so that the dial is placed at minimum 1 200 mm from floor and the handset may be reached by individuals in wheelchairs.

## **D-3.10 Handrails**

Handrails are used as a locational and mobility aid by blind and visually impaired people, and as a support for people with mobility

impairments. The handrail should be securely fitted to the wall to withstand heavy pressure. Handrails should turn in towards the wall at either end.

### **D-3.10.1**

Handrails should be approximately 900 mm from the floor. The rail should be easy to grip, having a circular section with a diameter of approximately 40 mm and fixed.

### **D-3.10.2**

To aid identification, the colour of the rail should contrast with the wall behind.

## **D-3.11 Elevators**

In a multi-storey building, elevators are essential to the successful functioning of physically disabled individuals. They shall conform to the requirements given in D-3.11.1 and D-3.11.2.

### **D-3.11.1**

Elevators shall be accessible to and usable by the physically disabled on the level that they use to enter the building, and at all levels normally used by the general public.

### **D-3.11.2**

Elevators shall allow for traffic by wheelchairs

## **D-3.12 Controls**

It is advantageous for wheelchair users if controls are placed at low level. For visually impaired people, they should be at eye-level.

### **D-3.12.1**

To enable wheelchair users to reach controls while not placing them too low for visually impaired people, controls should be in the

zone 800 mm to 1200 mm from the floor. It is advantageous if controls in, for example, lifts are placed at an angle of approximately 45° to the wall so that they are easier to read and operate. To cater for wheelchair users, controls should be placed not less than 400 mm from room corners. All the power and electric points should be placed at one metre above the floor level and should not project outside walls.

### D-3.12.2

Again, to cater for visually impaired people, controls should be colour-contrasted with backgrounds. Information should preferably be in relief for tactile reading.

### D-3.12.3

To aid operation for people with impaired co-ordination or impaired vision, switches, etc, should have large push plates.

### D-3.12.4

Controls for powered door openers to hinged doors should be located so that the doors do not conflict with wheelchairs, sticks, walking aids, etc.

### D-3.12.5

To facilitate operation for people with limited strength in arms and hands, handles should be easy to grip and turn.

## D-3.13 Identification

Appropriate identification of specific facilities within a building used by the public is particularly essential to the blind.

### D-3.13.1

Raised letters or numbers shall be used to identify rooms or offices.

### D-3.13.2

Such identification should be placed on the wall, to left of the door, preferably at a height of 1500 mm from the floor.

### D-3.13.3

Doors that are not intended for normal use, and that might prove dangerous if a blind person were to exit or enter by them, should be made quickly identifiable to the touch by knurling the door handle or knob.

## D-3.14 Warning Signals

### D-3.14.1

Audible warning signals shall be accompanied by simultaneous visual signals for the benefit of those with hearing disabilities.

### D-3.14.2

Visual signals shall be accompanied by simultaneous audible signals for the benefit of the blind. To assist blind people, lettering and symbols on signs should be in relief for tactile reading.

### D-3.14.3

Signs should be designed and located so that they are easy to read. For visually impaired people, signs should preferably be at eye-level and it should be possible to approach them closely. Text and symbols should be color-contrasted with the background. The letters should not be less than 12 run high.

### D-3.14.4

Signs should be well illuminated and surfaces should not cause mirroring or reflections. Signs should not be behind glass or similar materials.

### D-3.14.5

Information based on color codes only should be avoided; colorblind people may find them difficult to understand.

### D-3.15 Work Bench

This should be at least 800 mm wide, 600 mm deep and 650 mm to 700 mm high. For wheelchair users, the convenient height of work tops is between 750 mm and 850 mm; flexible provision is preferred. Further, for wheelchair access to a work bench, wash basin or table, a clear space for knees and footrests is needed.

### D-3.16 Hazards

Every effort shall be exercised to obviate hazards to individuals with physical disabilities.

#### D-3.16.1

Access panels or manholes in floors, walks, and walls may be extremely hazardous, particularly when in use, and should be avoided.

#### D-3.16.2

When manholes or access panels are open and in use, or when an open excavation exists on a site, particularly when it is in proximity of normal pedestrian traffic, barricades shall be placed on all open sides, at least 8.5 m from the hazard, and warning devices shall be installed in accordance with D-3.14.2.

#### D-3.16.3

Low-hanging door closers that remain within the opening of a doorway, when the door is open or that protrude hazardously into regular corridors or traffic ways when the door is closed, shall be avoided.

### D-3.16.4

Low-hanging signs, ceiling lights, and similar objects or signs and fixtures that protrude into regular corridors or traffic way shall be avoided. A minimum height of 2.1 m measured from the floor is recommended.

### D-3.16.5

Ramps shall be adequately lighted.

### D-3.16.6

Exit signs shall be in accordance with good practices.

### D-3.16.7

Equipment and materials causing allergic reactions should as far as possible be avoided in dwellings and buildings.

# Chapter -22 Relevant extract from Ministry of Urban Development and Poverty Alleviation (Delhi Division) Notification

New Delhi, the 28th August, 2002

S.O.917(E) - Whereas the issue of making suitable provision in the Building Bye-laws, 1983 to ensure that the public buildings that are erected in Delhi provide barrier free environment for the persons with disabilities has been under the consideration of the Government.

Whereas the following modifications / additions which the Central Government proposed to make in the Building Bye-laws 1983 in this regard were published for the public information vide Public Notice dated 26th March, 2002 and were advertised in the leading newspapers on 4th April, 2002. In all 7 objections / suggestion were received and they were examined by a Committee under the Convenorship of Chief Planner of Town & Country Planning Organisation.

Whereas after thorough consideration of the report, Central Government has decided to make the following Modifications/additions in the Building Bye-laws, 1983.

Now, therefore, in exercise of the powers conferred by sub-section (2) of section 11A of Delhi Development Act, 1957, the Central Government hereby make the following Modifications/additions to the Building Bye-laws 1983 with effect from the date of publication of this Notification in the Gazette of India.

Modification: To provide barrier free environment in the public building for persons with disabilities.

## 2. Definitions:

### 2.91 Non-ambulatory disabilities:

Impairments that, regardless of cause or manifestation, for all practical purposes, confine individuals to wheelchairs.

### 2.92 Semi-ambulatory disabilities:

Impairments that cause individual to walk with difficulty or insecurity. Individuals using braces or crutches, amputees, arthritis, spastics and those with pulmonary and cardiac ills may be semi-ambulatory,

**2.93 Hearing disabilities:** Deafness or hearing handicaps that might make an individual insecure in public areas because he is unable to communicate or hear warning signals.

**2.94 Sight Disabilities:** Total blindness or impairment affecting sight to the extent that the individual functioning in public areas is insecure or exposed to danger.

**2.95 Wheel Chair:** Chair used by disabled people for mobility

- i. Size of Small Wheel Chair: 750 x 1050 mm
- ii. Size of Large Wheel Chair: 800 x 1500 mm

## 30.0 To provide facilities in the public building for the disabled persons.

**30.1 Scope:** These bye-laws are applicable to all building, recreation areas & facilities used by public. It does not apply to private domestic residences.

**30.1.1 Site planning:** Level of the roads, access paths & parking areas shall be described in the plan along with specification of materials. Every building should have at least one access to main entrance / exist to the disabled, which shall be indicated by proper signage. This entrance shall be approached through a ramp together with stepped entry. The ramp should have a landing after every 9 Metre run and in front of the doorway. Minimum size of landing shall be 1000 x 2000 mm.

**30.1.2 Access path / walk way:** Access path from plot entry and surface parking to building entrance shall be minimum of 1800 mm wide having even surface without any step. Slope, if any shall not have gradient greater than 5%. Selection of floor material shall be made suitably to attract or to guide visually impaired persons (limited to floor material whose colour texture is conspicuously different from that of the surrounding floor material or the material that emit different sound to guide visually impaired persons. Finishes shall have a non-slip surface with texture traversable by a wheel chair. Curbs wherever provided should blend to common level.

**30.1.3 Parking:** For parking of vehicles of disabled people the following provisions shall be made:

- a. Surface parking for two Equivalent Care Spaces (ECS) shall be provided near entrance for the physically handicapped persons with maximum travel distance of 30 metre from building entrance.
- b. The width of parking bay shall be minimum 3.6 metre.
- c. The information stating that the space is reserved for wheel chair users shall be conspicuously displayed.
- d. Guiding floor materials shall be provided or a device which guides visually impaired persons with audible signals or other devices which serves the same purpose shall be provided.

**30.2 Building requirements:** The specified facilities for the buildings for disabled persons shall be as follows:

1. Approach to plinth level

2. Corridor connecting the entrance / exist for the handicapped
3. Stair-ways
4. Lift
5. Toilet
6. Drinking water

Braille signage shall be provided at the above specified facilities.

### 30.2.1 Approach to plinth Level:

Ramp shall be provided with non-slip material to enter the building minimum clear width of ramp shall be 1800 mm with maximum gradient 1:12, between top and bottom of the ramp. Length of ramp shall not exceed 9.00 metres having 800 mm high handrail on both sides extending 300 mm beyond the ramp. Minimum gap from the adjacent wall to the handrail shall be 50 mm.

Minimum clear opening for the entrance door shall be 1000 mm. Threshold shall not be raised more than 12 mm.

For stepped approach, size of tread shall not be less than 300 mm and maximum riser shall be 150 mm. Provision of 800 mm high handrails on both sides of the stepped approach similar to the ramped approach shall be made.

### 30.2.2 Corridor connecting the entrance / exist for the disabled:

The corridor connecting the entrance / exist for handicapped leading directly outdoors to a place where information concerning the overall use of the specified building can be provided to visually impaired persons either by a person or by signs, shall be provided as follows:

- a. Guiding floor materials shall be provided or devices that emit sound to guide visually impaired persons.



- b. The minimum width shall be 1500 mm.
- c. In case there is a difference of level, slop ways shall be provided with a slope of 1:12
- d. Handrails shall be provided for ramps/ slop ways.

**30.2.3 Stairways:** Stairways with open riser & provision of nosing are not permitted in such building.

**30.2.4 Lifts:** Whenever lift is required as per bye-laws, provisions of at least one lift shall be made for the wheel chair user with the following car dimensions of lift recommended for passenger lift for 13 persons capacity by Bureau of Indian Standard

Clear internal depth 1100 mm

Clear internal width 2000 mm

Entrance door width 910 mm

1. A handrail not less than 600 mm long at 900 mm above floor level shall be fixed adjacent to the control panel.
2. The lift lobby shall be an inside measurement of 1800 mm x 2000 or more.
3. The Braille signage will be posted outside the lifts.
4. Operational details of lifts shall confirm to the National Building Code (NBC) and will be the responsibility of designer as well as manufacturer.

**30.2.5 Toilets:** One special WC in a set of toilet shall be provided for the use of handicapped with essential provision of washbasin near the entrance for the handicapped.

- a. The minimum size shall be 1500 mm x 1750 mm.
- b. Minimum clear opening of the door shall be 900 mm and the door shall swing out / sliding type.
- c. Suitable arrangement for vertical / horizontal handrails with 50 mm clearance from wall shall be made in the toilet.
- d. The WC seat shall be 500 mm from the floor.

**8.6 Refuge:** An alternative to immediate evacuation of a building via staircases and/or lifts is the movement of disabled persons to areas of safety within a building. If possible, they could remain there until the fire is controlled and extinguished or until rescued by fire fighters.

It is useful to have the provision of a refuge area, usually at the fire protected stair landing on each floor that can safely hold one or two wheelchairs.

\* Have doorways with clear opening width of 900 mm and complying with Section 4.6; and

\* Have an alarm switch installed between 900 mm and 1200 mm from the floor level.

{No.K-12016/5/79/DDLA/VA/IB Vol.IX(Pt.)}

**NISHA SINGH**, Director (DD)



**CENTRAL PUBLIC WORKS DEPARTMENT**  
Nirman Bhawan, New Delhi